

INDESSE Industry
VCIN AC/EC

EN INSTALLATION AND OPERATION

P01-0302-0515-01 v3



8595102264341



EN	INSTALLATION AND OPERATION	3
	BEFORE YOU BEGIN	4
	UNPACKING	5
	MAIN PARTS	6
	SPARE PARTS	7
	DIMENSIONS	8
	TECHNICAL SPECIFICATIONS.....	9
	INSTALLATION	10
	FIRST USE	30
	MAINTENANCE	31
	TROUBLESHOOTING	32
	PRODUCT DISPOSAL	34
	IN CONCLUSION	35

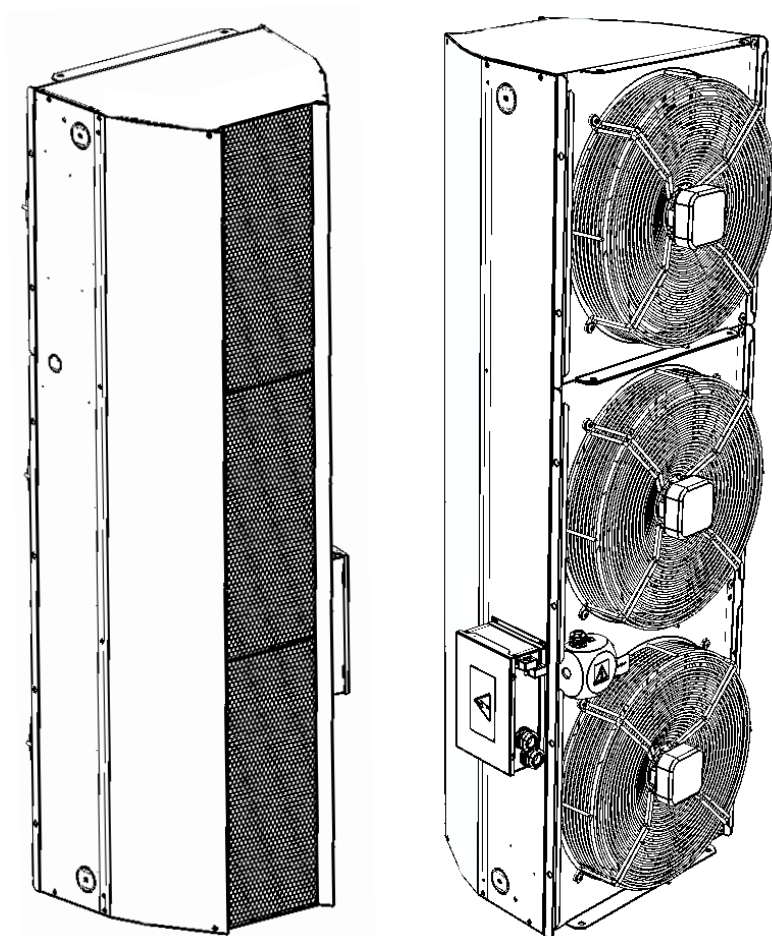





INDESSE *Industry*

VCIN

EN INSTALLATION AND OPERATION

1. BEFORE YOU BEGIN

Symbols are used in the text for better orientation in the manual.
The following table shows their illustrations and meanings:

Symbol	Meaning
 ATTENTION!	Warning or caution
 IMPORTANT NOTICE!	Important information
 YOU WILL NEED	Practical tips and information
 Technical information	More technical information
	Link to another part of the manual



This manual contains important instructions for the proper installation of the **INDESSE Industry** air curtain. Before the installation of the air curtain, please read all these instructions and follow them! The manufacturer reserves the right to make changes, including to the technical documentation without prior notice. Please save this manual for future use. Consider this manual as a part of the product.

This manual contains important instructions for the safe connecting of the air curtain. Before connecting the unit, please read all instructions below and follow them! The manufacturer reserves the right to make changes, including to the technical documentation without prior notice. Please save this manual for future use. Consider this manual to be part of the product.

EC DECLARATION OF CONFORMITY

The product has been designed, manufactured, placed on the market, complies with all applicable regulations and is in compliance with the requirements of the directives of the European Parliament and the Council, including amendments to the proposal, under which it was classified. Under normal conditions and in the instruction manual for the intended use and installation, it is safe. The harmonized European standards referred to in the relevant EC declaration of conformity have been applied in the assessment.

For the current and full version of the EC Declaration of Conformity, please see www.2vv.cz or the enclosed CD. (when attached to the packaging).

2. UNPACKING



2.1 CHECK DELIVERY



- After delivery, immediately check whether the packaged product is damaged. Summon the carrier in case of damage to the packaging. If a claim is not lodged in a timely manner, it is not possible to enforce potential claims in the future.
- Check if your ordered product type agrees. In case of disagreement do not unpack the air curtain and report the defect to the supplier immediately.
- After unpacking, check that the air curtain and all components are in order. If in doubt, contact the supplier.
- Never install a damaged air curtain.
- If you do not unpack the air curtain immediately after delivery, it must be stored indoors in a dry environment with an ambient temperature from **+ 0 ° C to + 40 ° C**.

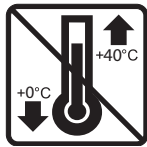

	All packaging materials are environmentally friendly and can be reused or recycled. Contribute to protection of the environment actively and ensure the proper disposal and recycling of packaging materials.	
--	---------------------------------------------------------------------------------------------------------------------------------------------------------------------------------------------------------------	--

2.2 UNPACK THE AIR CURTAIN

Packaged accessories:
2 x Connecting part

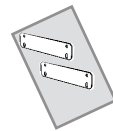

1x Manual

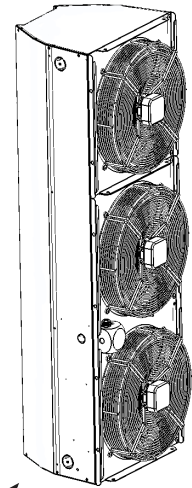

1x Air curtain

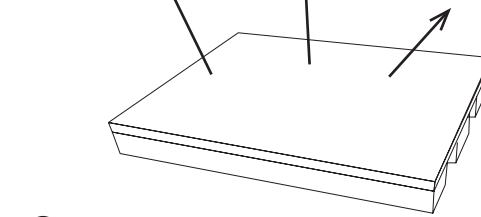

- If the air curtain was transported at temperatures below 0 ° C, it is necessary to leave it in the operating environment for at least 2 hours without turning on after unpacking, for temperature compensation inside the air curtain to occur.

○○ **3. MAIN PARTS**

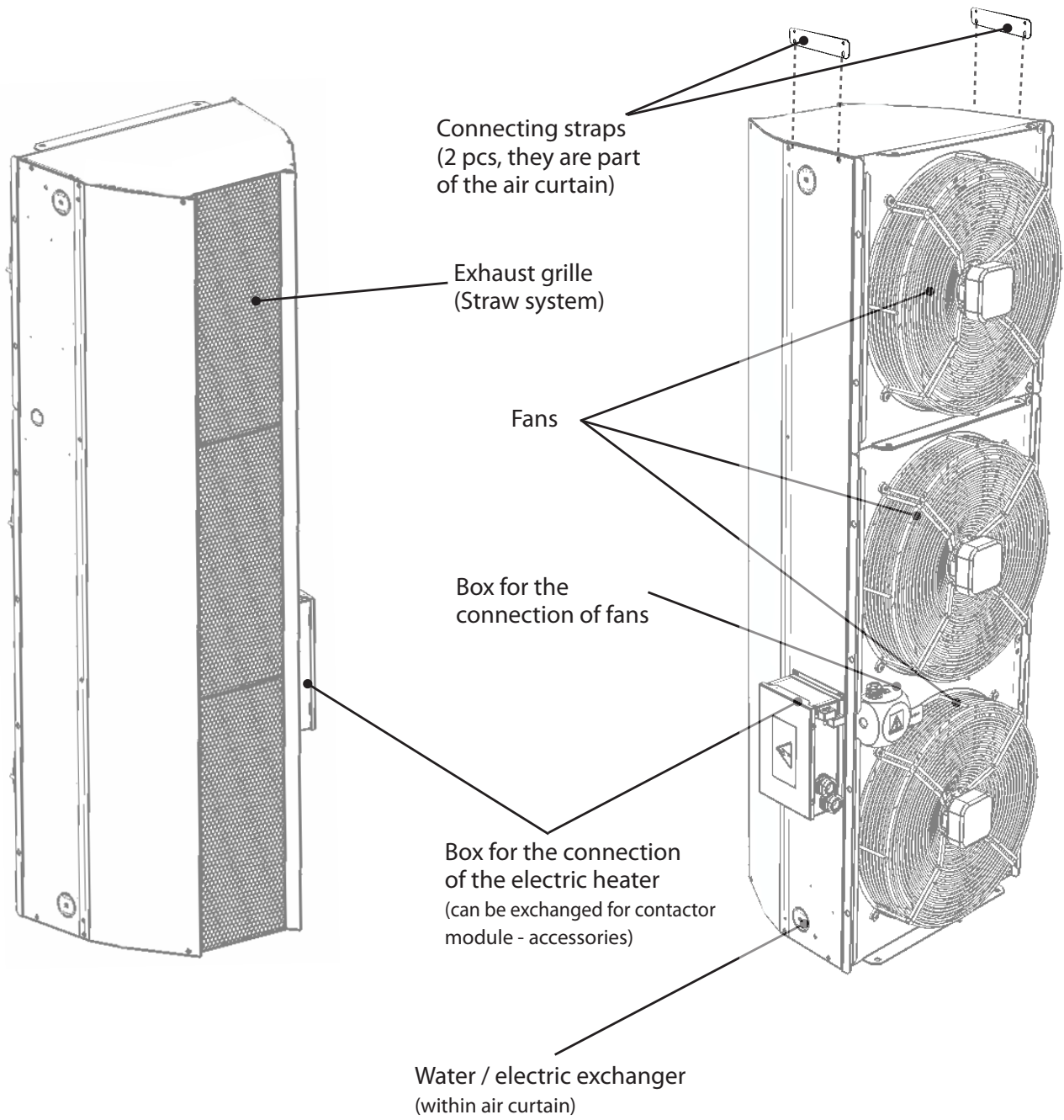

4. SPARE PARTS

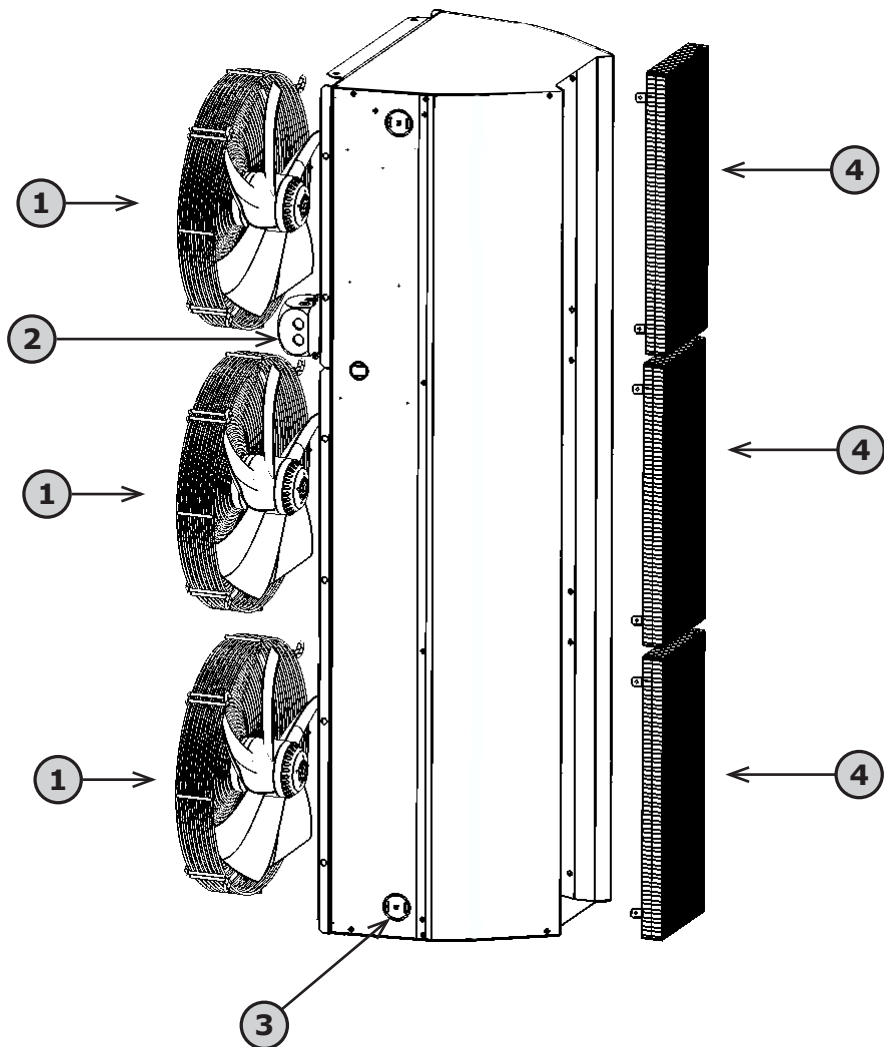

Nr.	Description	VCIN2A150		VCIN2A200		VCIN2A250	
		code	pc/air curtain	code	pc/air curtain	code	pc/air curtain
①	Motor AC	ND-VEN-AC-AX-YWF4E-450B-V	3	ND-VEN-AC-AX-YWF4E-450B-V	4	ND-VEN-AC-AX-YWF4E-450B-V	5
	Motor EC	ND-VEN-EC-AX-EC102-A450	3	ND-VEN-EC-AX-EC102-A450	4	ND-VEN-EC-AX-EC102-A450	5
②	Electro-installation box	ND-VCIN1-KRAB-VENT	1	ND-VCIN1-KRAB-VENT	1	ND-VCIN1-KRAB-VENT	1
③	Water exchanger	ND-VCIN1-VV-15	1	ND-VCIN1-VV-20	1	ND-VCIN1-VV-25	1
	Electric exchanger	ND-VCIN1-EL-VYM	3	ND-VCIN1-EL-VYM	4	ND-VCIN1-EL-VYM	5
④	Straw system including a frame	ND-VCIN1-VOST	3	ND-VCIN1-VOST	4	ND-VCIN1-VOST	5

5. DIMENSIONS

VCIN...-E1..

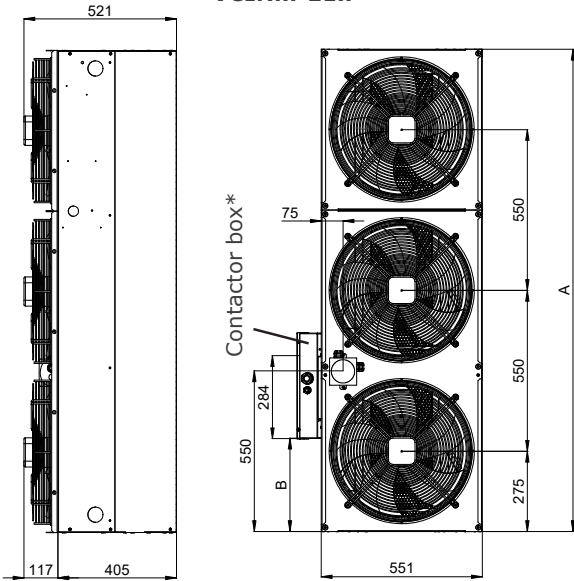

VCIN	A [mm]	B [mm]
150	1650	320
200	2200	870
250	2750	870

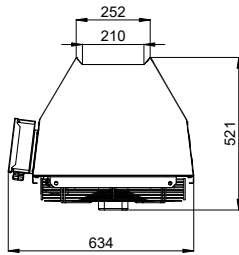

* - Accessories

VCIN...-S0..

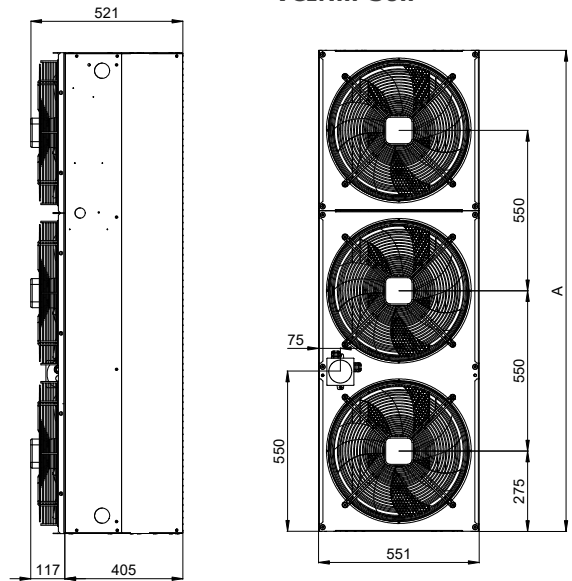

VCIN	A [mm]
150	1650
200	2200
250	2750

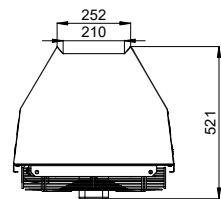

VCIN...-V2..

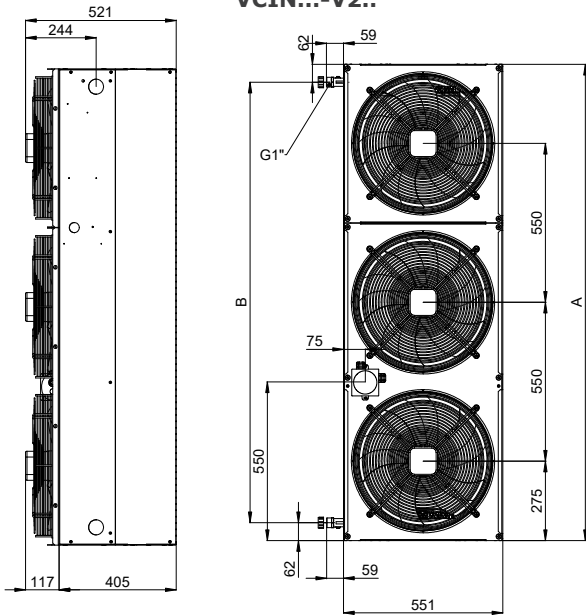

VCIN	A [mm]	B [mm]
150	1650	1526
200	2200	2076
250	2750	2626

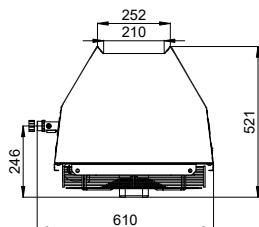

VCIN...-P2..

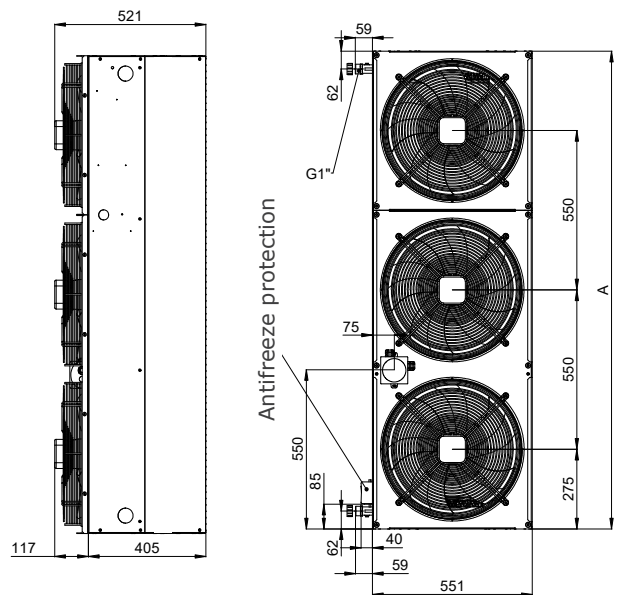

VCIN	A [mm]
150	1650
200	2200
250	2750

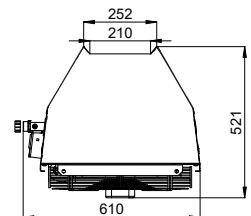

6. TECHNICAL SPECIFICATIONS

AC

Type of air curtain	Postflow *	Air output [m ³ /h]	Noise [dB(A)]**		Heater output *** [kW]	Heater power supply [V/A]	Fans power supply [V/A]	Weight [kg]
	[m]		3m	5m				
VCIN...150-S0AC	7,5	11550	67,5	63,0	-	-	230/3,9	51
VCIN...150-V2AC		10300	67,5	63,1	91,3***	-	230/3,9	60
VCIN...150-P2AC		11550	67,5	63,0	24,3	400/35,2	230/3,9	55
VCIN...150-E1AC		15100	69,3	64,9	-	-	230/5,1	69
VCIN...200-S0AC	8,0	13700	68,4	64,0	123***	-	230/5,4	78
VCIN...200-V2AC		15100	69,3	64,9	32,4	400/47,0	230/5,1	74
VCIN...200-P2AC		18500	71,1	66,7	-	-	230/6,5	83
VCIN...200-E1AC		17000	70,0	65,5	154***	-	230/6,7	98
VCIN...250-S0AC	7,5	18500	71,1	66,7	40,5	400/58,6	230/6,5	89
VCIN...250-V2AC		19000	#	#	-	-	230/6,45	83
VCIN...250-P2AC		17500	#	#	#	-	230/6,85	98
VCIN...250-E1AC		19000	#	#	#	400/58,6	230/6,45	89

EC

Type of air curtain	Postflow *	Air output [m ³ /h]	Noise [dB(A)]**		Heater output *** [kW]	Heater power supply [V/A]	Fans power supply [V/A]	Weight [kg]
	[m]		3m	5m				
VCIN...150-S0EC	7,5	11400	#	#	-	-	230/3,87	51
VCIN...150-V2EC		10500	#	#	#	-	230/3,95	60
VCIN...150-P2EC		11400	#	#	#	400/35,2	230/3,87	55
VCIN...150-E1EC		15200	#	#	-	-	230/5,16	69
VCIN...200-S0EC	8,0	13700	#	#	#	-	230/5,27	78
VCIN...200-V2EC		15200	#	#	#	400/47,0	230/5,16	74
VCIN...200-P2EC		19000	#	#	-	-	230/6,45	83
VCIN...200-E1EC		17500	#	#	#	-	230/6,85	98
VCIN...250-S0EC	7,5	19000	#	#	#	400/58,6	230/6,45	89
VCIN...250-V2EC		19000	#	#	-	-	230/6,45	89
VCIN...250-P2EC		17500	#	#	#	-	230/6,85	98
VCIN...250-E1EC		19000	#	#	#	400/58,6	230/6,45	89

* The distance at which the medium speed of air flow drops to 3 m / s.

(under optimal conditions and max. output of device, measured according to ISO 27327-1))

** Acoustic pressure at a distance of 3 m or 5 m from the air curtain and parameter Q = 2.

*** With the temperature water gradient 110/80 °C and the intake air temperature + 15 °C.

Other specifications can be found in the technical sheet of the product

7. INSTALLATION

POSSIBLE WAYS OF INSTALLATION - VERTICAL INSTALLATION

Vertical installation, side view, with a mobile base and a wall bracket

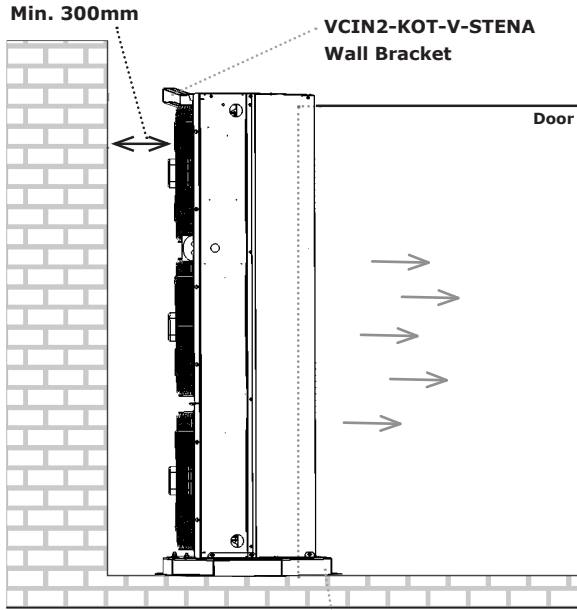

Vertical installation, side view, firmly attached to the floor

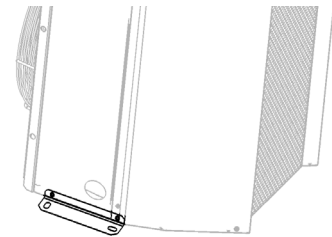
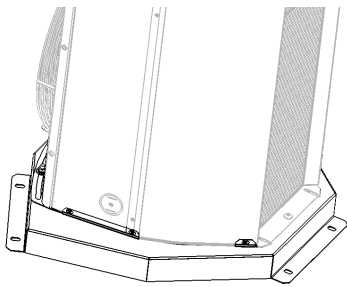
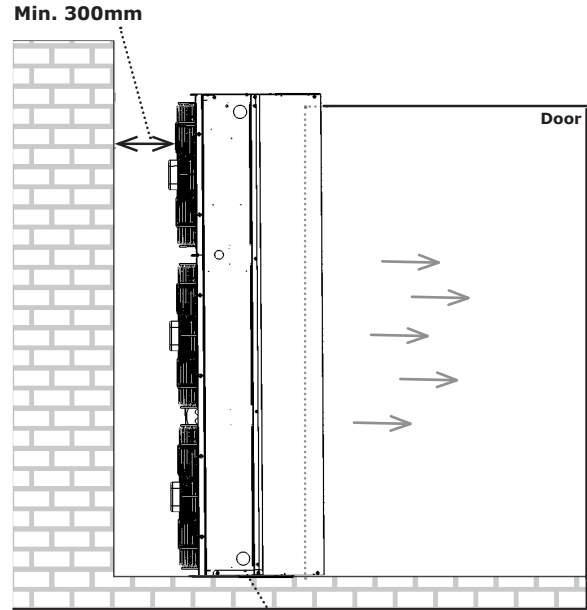

Installation on one side

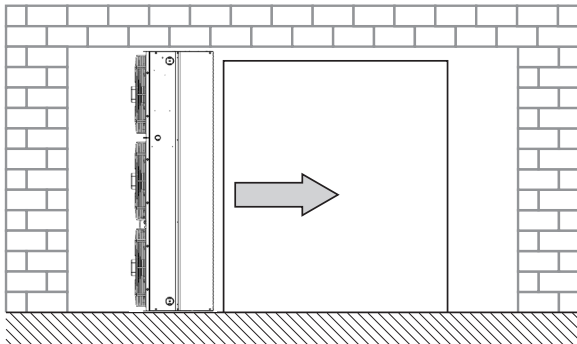

Installation from both sides to achieve a better screening effect

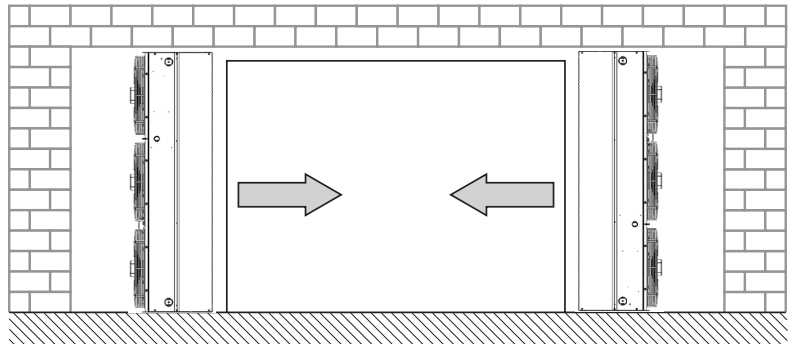

7. INSTALLATION



POSSIBLE WAYS OF INSTALLATION - HORIZONTAL INSTALLATION

Horizontal installation on the wall

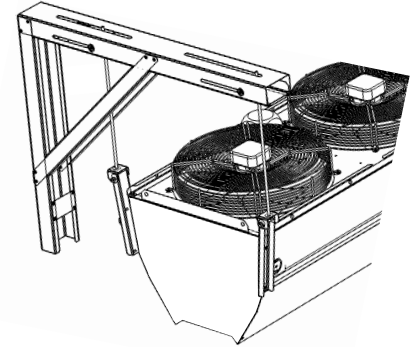
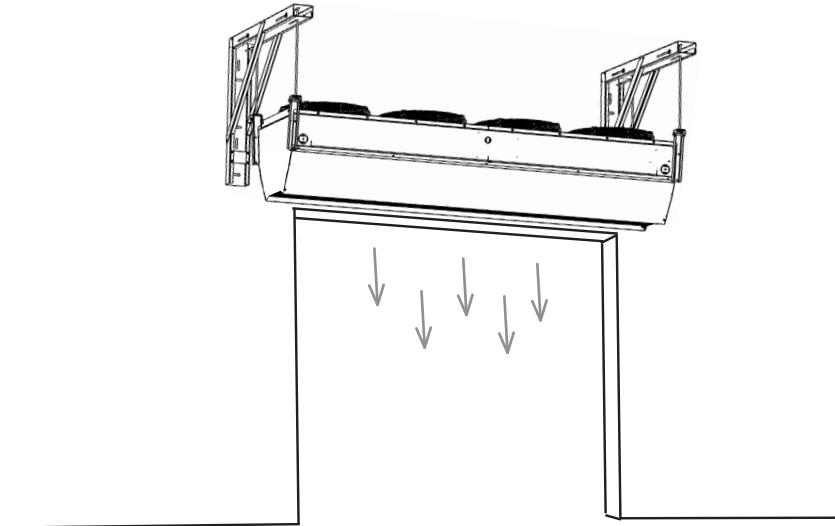

Movable wall bracket
VCIN2-KOT-H-STENA

⚠️ **THREADED RODS ARE NOT SUPPLIED, THEY MUST BE ENSURED.** ⚠️

Horizontal installation on the ceiling

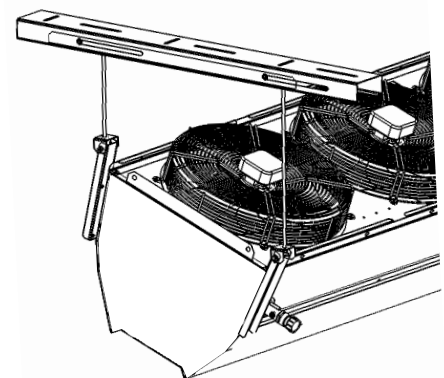
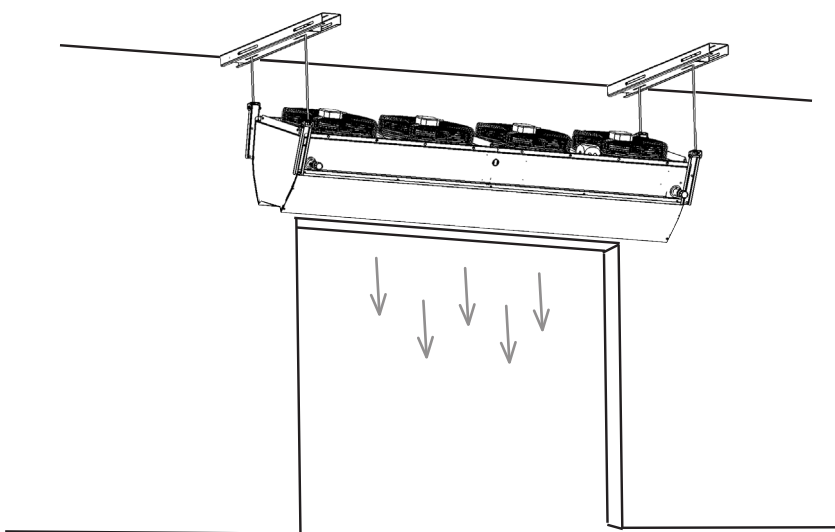

Movable ceiling bracket
VCIN2-KOT-H-STROP

⚠️ **THREADED RODS ARE NOT SUPPLIED, THEY MUST BE ENSURED.** ⚠️

7. INSTALLATION

Installation dimensions - horizontal installation

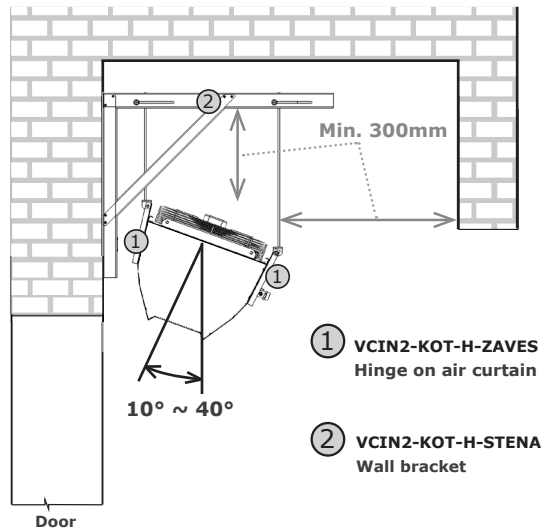
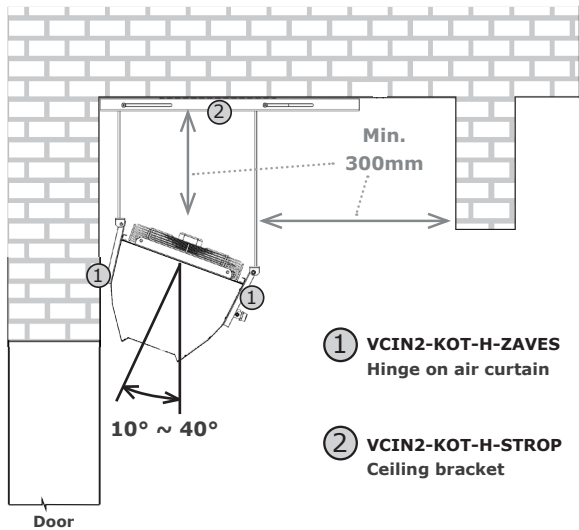

- The air curtain must be aligned in the horizontal level!
- It must be operated indoors, in covered and dry areas with ambient temperatures from + 5 ° C to + 40 ° C and a relative humidity of 80%.
- The air curtain is not intended for the transport of air containing flammable or explosive mixtures, chemical fumes, coarse dust, soot, grease, poisons, germs etc. e.g. car washes, fuel storage spaces, spaces for livestock breeding.

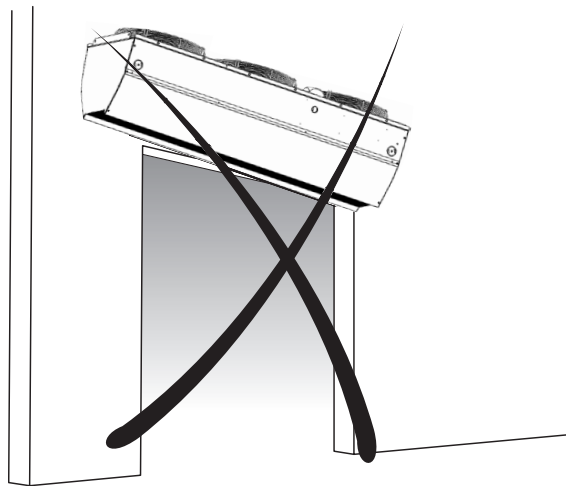
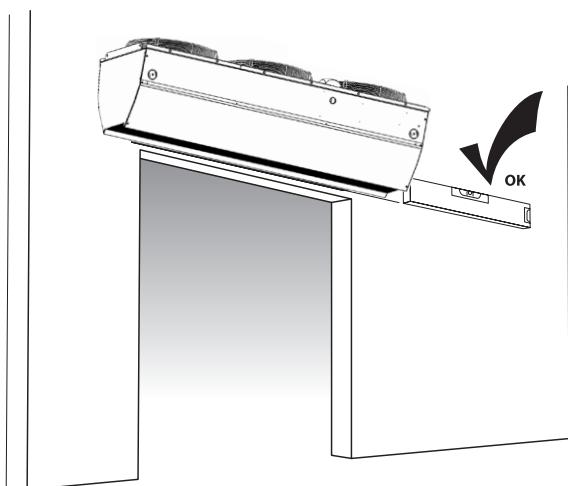

7. INSTALLATION

Installation dimensions - vertical installation

Floor plan of vertical installation

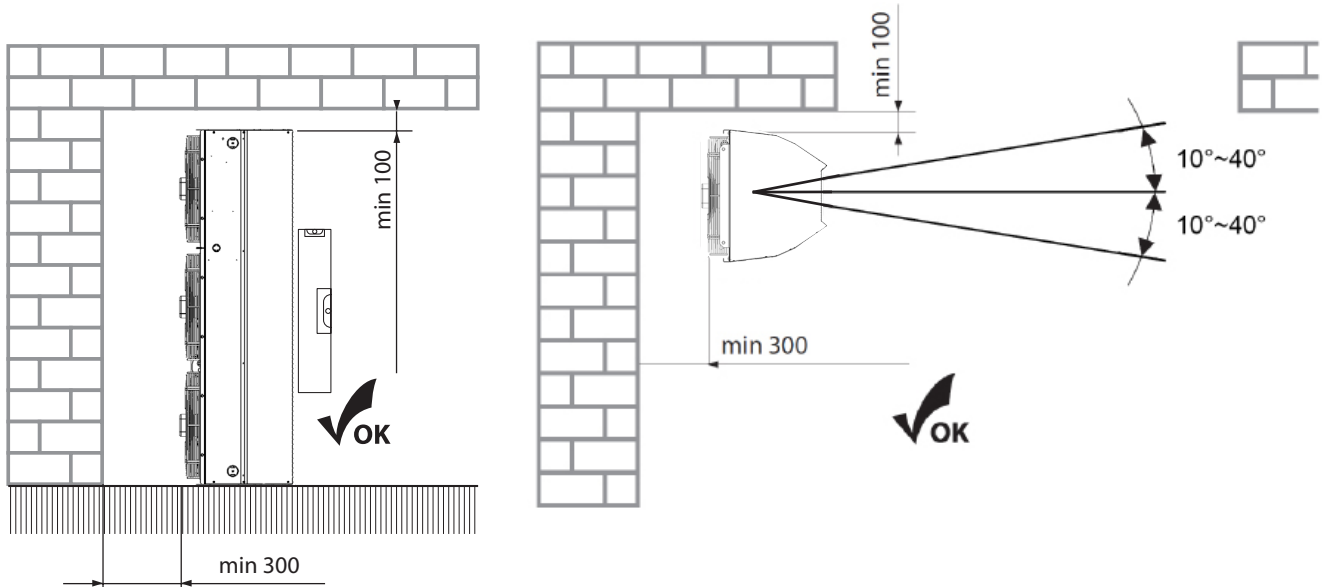

- The air curtain must be aligned in the vertical level!
- The bottom air curtain must stand on a flat, stable surface.
- It must be operated indoors, in covered and dry areas with ambient temperatures from + 5 ° C to + 40 ° C and a relative humidity of 80%.
- The air curtain is not intended for transport of air containing flammable or explosive mixtures, chemical fumes, coarse dust, soot, grease, poisons, germs etc.
- For proper operation, it is recommended that the air curtain is rotated by exhaust out of 10 degrees.

7. INSTALLATION

Spacing distances

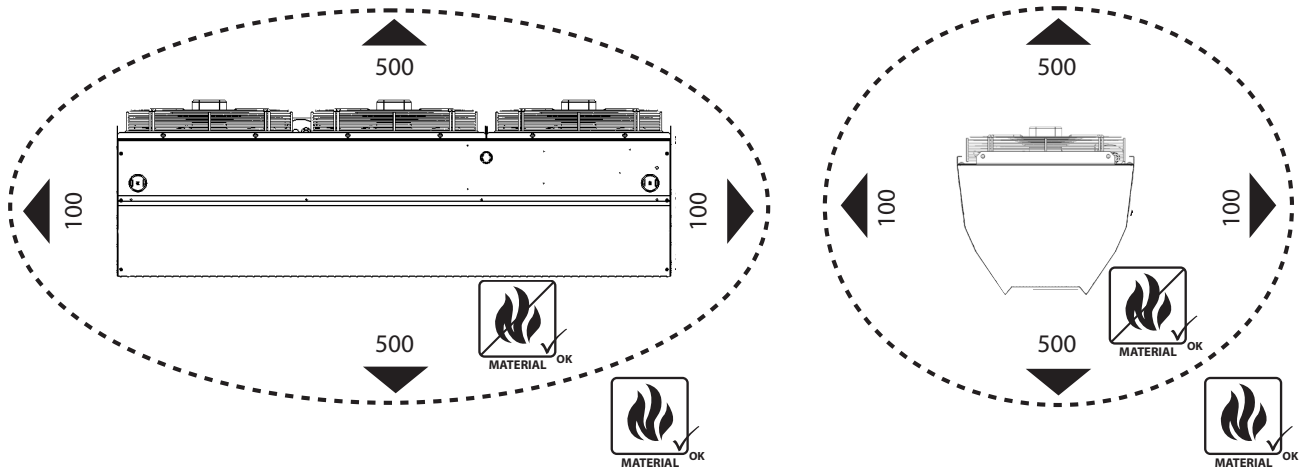

Only non-flammable materials (do not burn, do not glow, do not carbonize) or not easily flammable material (do not burn, mostly glow - e.g. drywall) **may be at a distance of 100 mm from the air curtain in all directions.** These materials must **not cover the intake or exhaust vents.**

For a safe distance of surfaces of building construction and objects made of flammable materials from the air curtains with electric heating, it applies:

- The safe distance of flammable materials in the direction of the main airflow (i.e. in front of the intake grille and behind the exhaust slot) is **500 mm.**
- The safe distance of flammable materials above the air curtain is **500 mm.**
- The safe distance of flammable materials in all other directions is **100 mm.**

7. INSTALLATION

The modular assembly of air curtains

From the individual modules of **INDESSE Industry** air curtains we can create assemblies depending on the requirements for the desired length, air power or heating capacity of the assembly. When installing and greater height of assembly it is necessary to take into account the weight that will affect the bottom air curtain. Individual modules are connected through connecting straps. Two pieces of straps are part of each **INDESSE Industry** air curtain.



Connecting straps don't have connecting bolts. It is necessary to ensure **4 pieces M5x10mm** for each connecting straps to connect them.

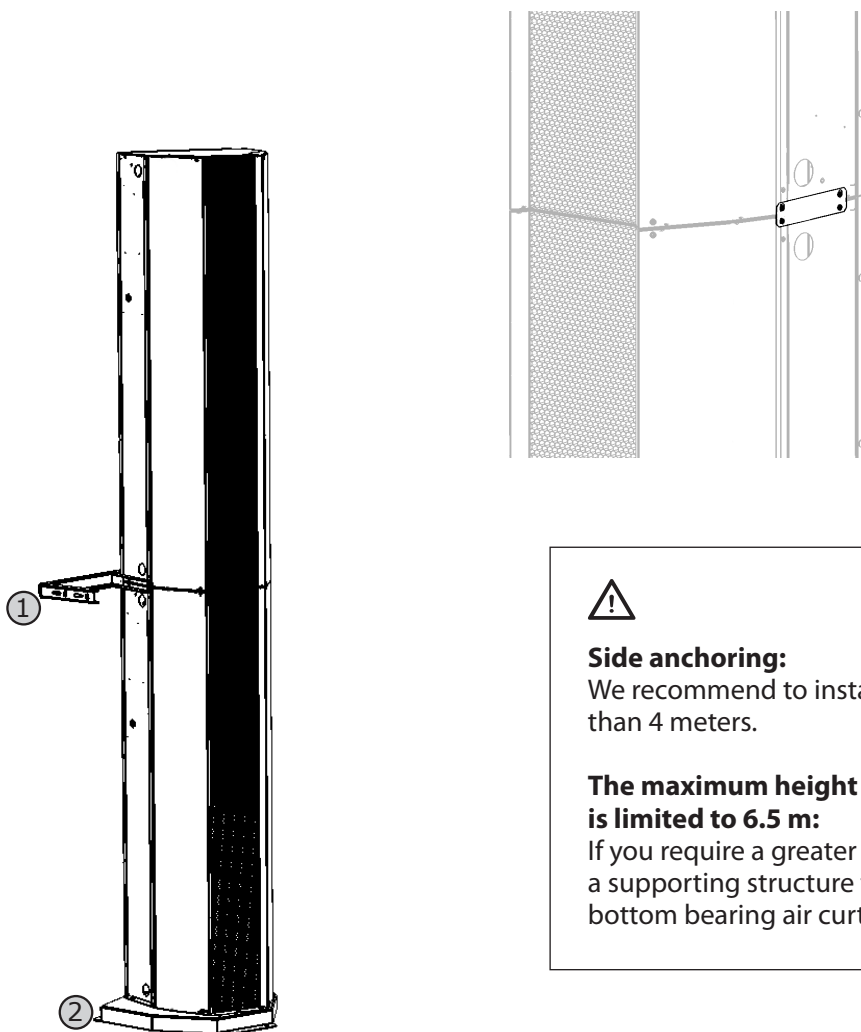

Side anchoring:

We recommend to install from a height greater than 4 meters.

The maximum height of the air curtains is limited to 6.5 m:

If you require a greater height, you must create a supporting structure to avoid damage of the bottom bearing air curtain.

Example: Vertical assembly 2x VCIN250

- ① wall bracket - that can be used as a connecting link of 2 modules
- ② mobile base

7. INSTALLATION

Dimensions and weights of air curtains

Air curtain	Weight (kg) 1pc of air curtain	Dimension A (mm)
VCIN...150-S0...	51	1650
VCIN...150-V2...	60	1650
VCIN...150-P2...	60	1650
VCIN...150-E1...	55	1650
VCIN...200-S0...	69	2200
VCIN...200-V2...	78	2200
VCIN...200-P2...	78	2200
VCIN...200-E1...	74	2200
VCIN...250-S0...	83	2750
VCIN...250-V2...	98	2750
VCIN...250-P2...	98	2750
VCIN...250-E1...	89	2750

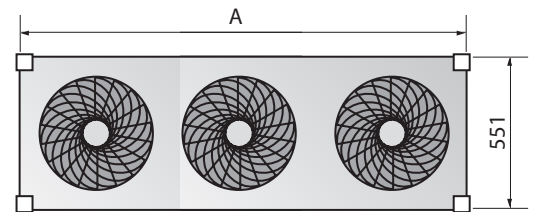

⚠ Hanging must bear the weight of the air curtain! Consider the properties of the bearing material!

Fasten the hanging consoles to the air curtain

⚠ Hanging consoles are optional accessories of the air curtain and they must be ordered.

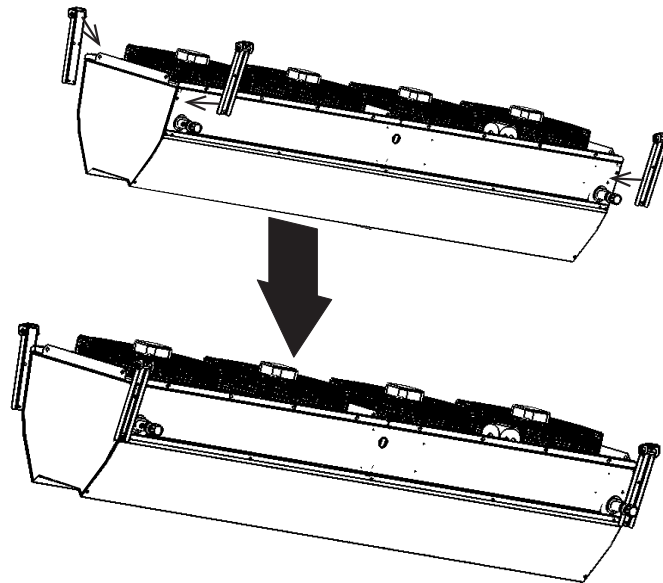

Fasten the air curtain to the hanging construction / threaded rods



Due to the weight of the air curtain it is required to use suitable lifting equipment for its lifting (forklift, etc.).



7. INSTALLATION

Install threaded rods

 Threaded rods aren't accessories of the air curtain and it is necessary to ensure them.

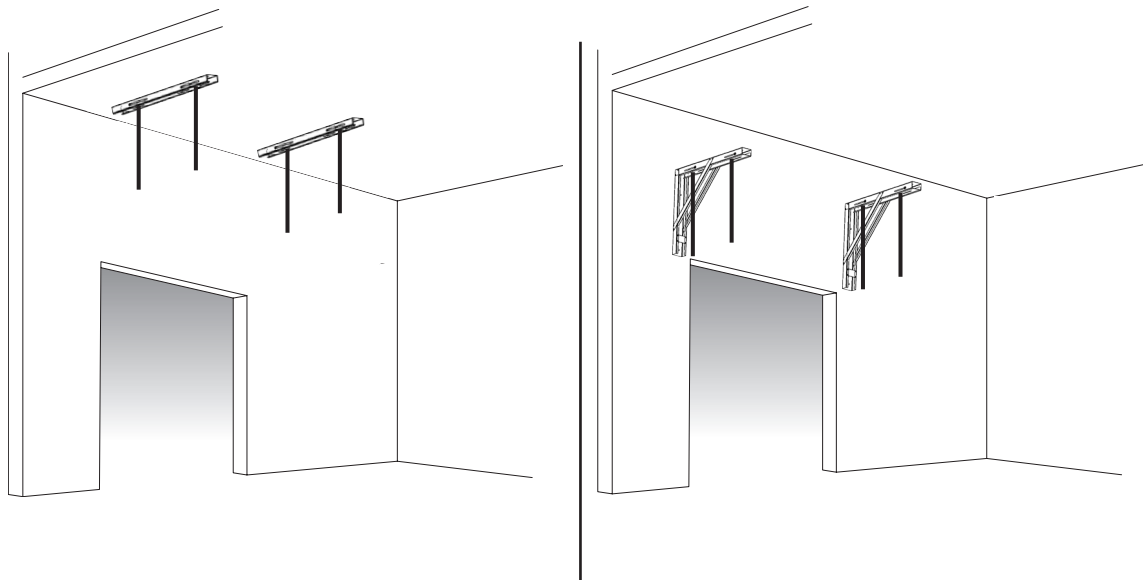

Install the air curtain using fork lift platform

TIP: If the air curtain is packed horizontally, you can leave it in the package and lift the entire assembly up. After the securing of the air curtain you bring the empty packaging down

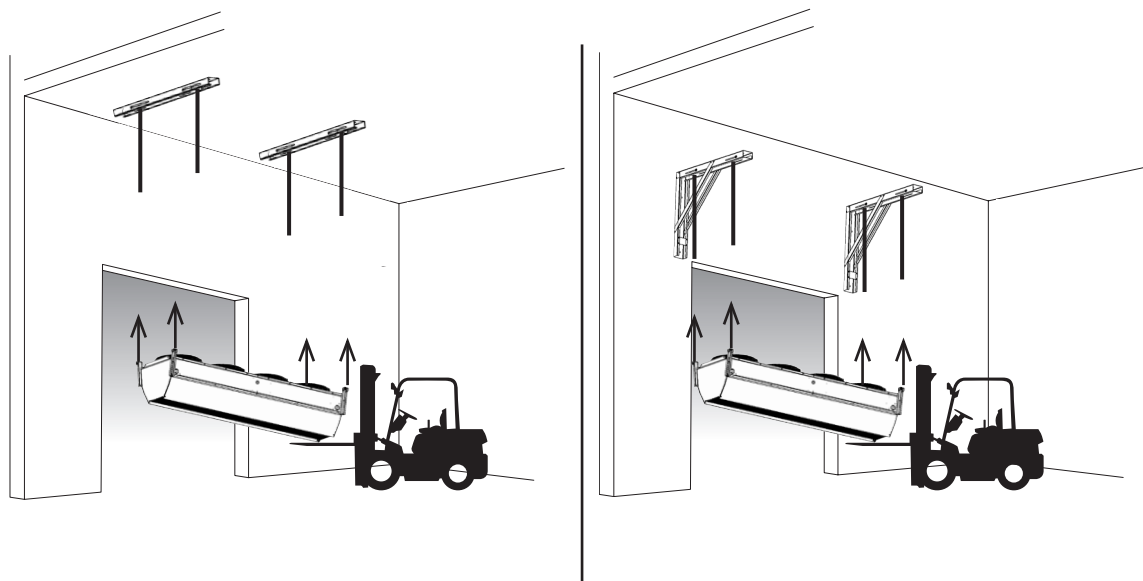

7. INSTALLATION



Fasten to prepared threaded rods

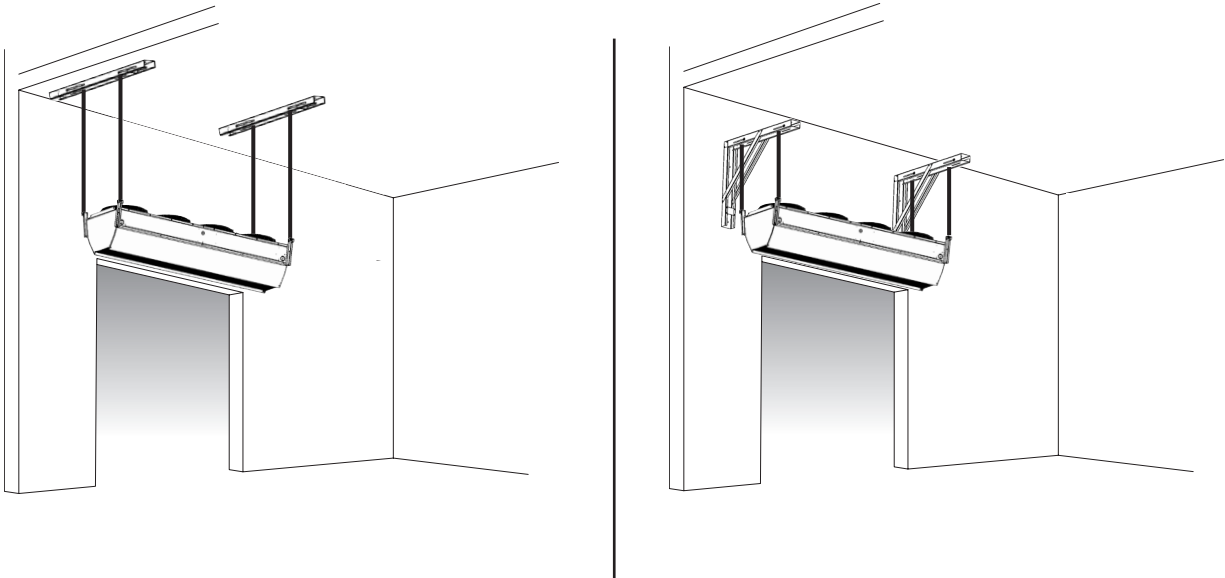

Detail of fixing

 Secure properly against spontaneous loosening or falling

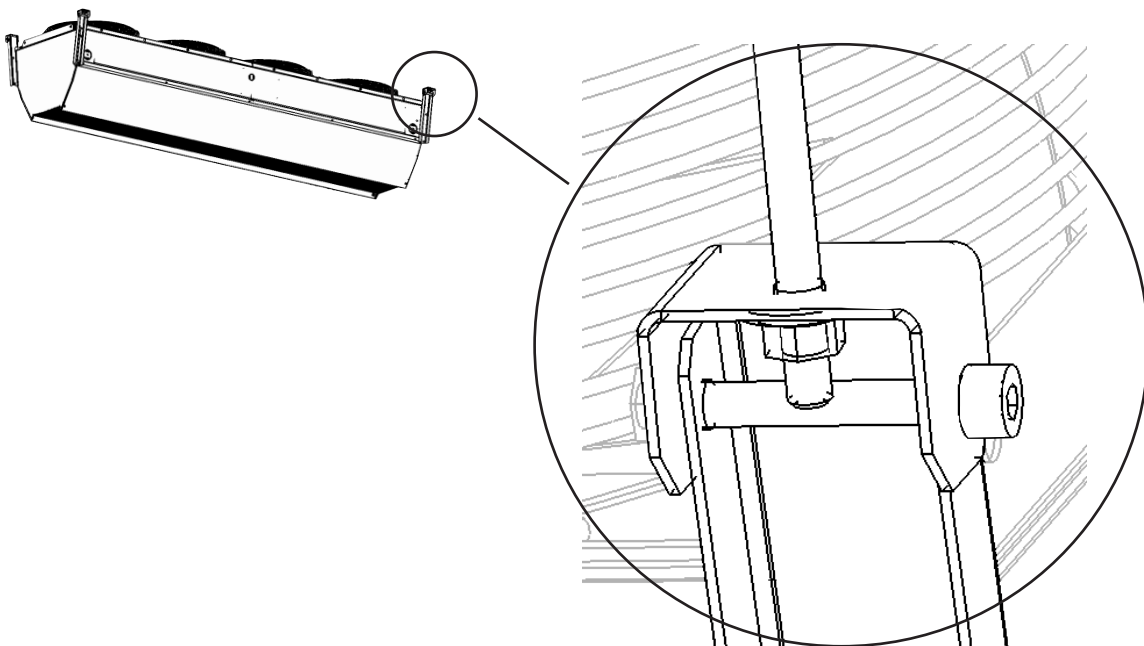

7. INSTALLATION

Set the desired counterblow

 The setting of the counterblow is very important and influences the effect of screening. The recommended counterblow may be in the range 10-40°.

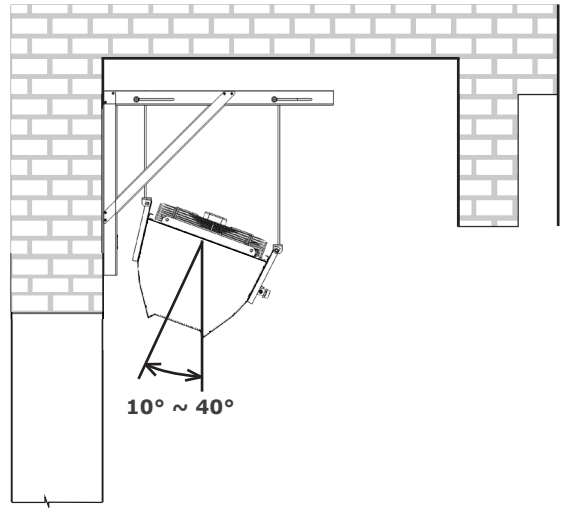
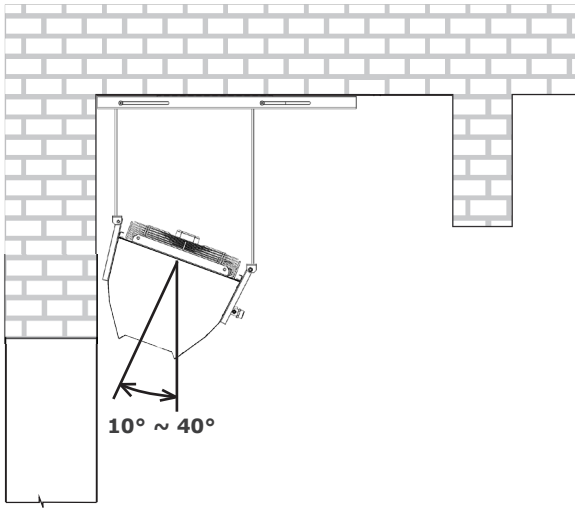

7. INSTALLATION



VERTICAL FIXING OF THE AIR CURTAIN - MOVABLE BRACKET



Floor brackets are optional accessories of the air curtain and it is necessary to order them.

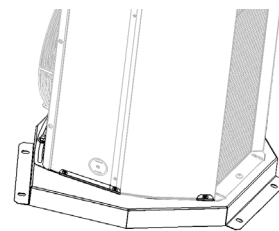

- 1) Measure the holes by using the holes in the bracket, which must be drilled into the floor

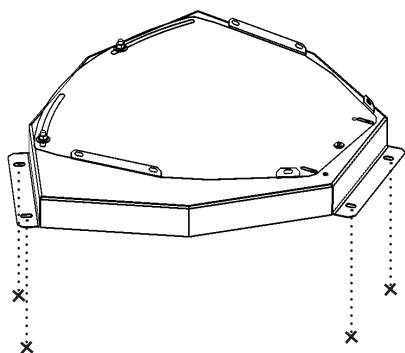

- 2) Spread the bracket and screw the bottom part to the ground



Installation material is not part of the air curtain. Ensure good quality material with respect to the installation place

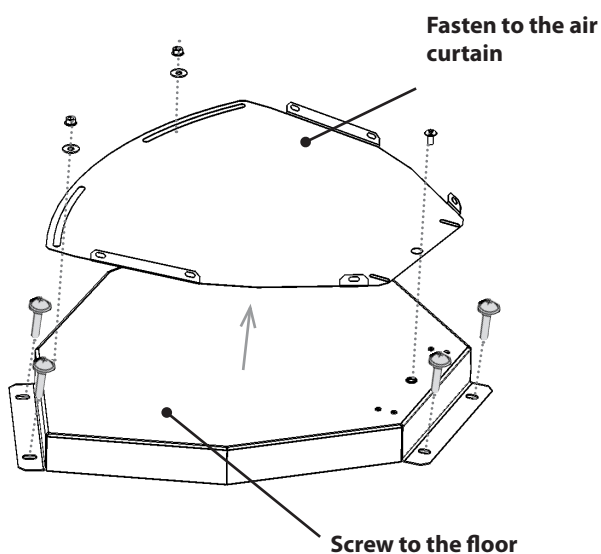

- 3) Fasten the upper part of the bracket to the air curtain



Připevněte pomocí dodaných šroubů k tomuto podstavci (6ks)

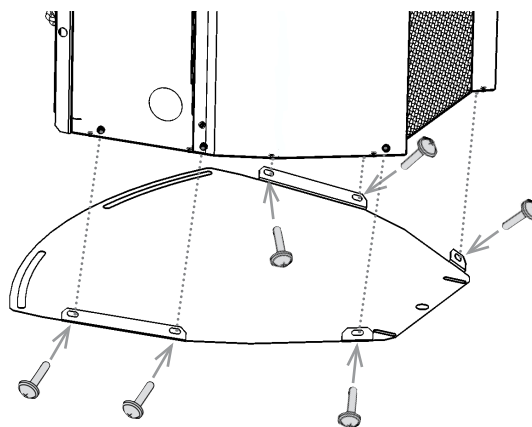

- 4) Fasten the upper part of the bracket to the bottom part of the bracket



Fasten by using screws supplied to this base

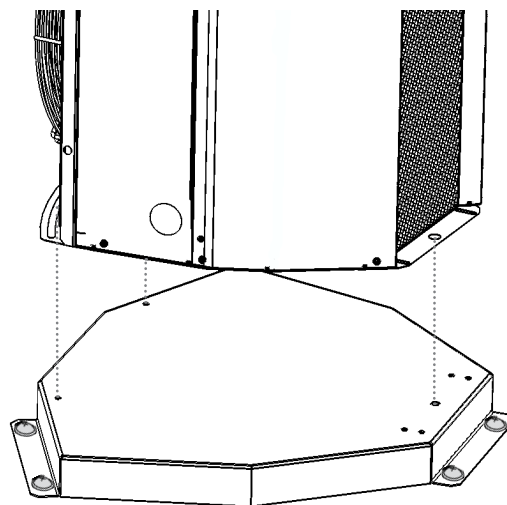

7. INSTALLATION

VERTICAL FIXING OF THE AIR CURTAIN – MOBILE BRACKET

! Floor brackets are optional accessories of the air curtain and it is necessary to order them.

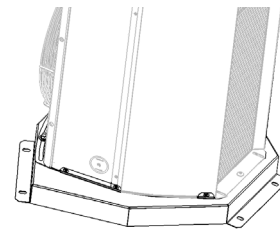

5) If the height of the air curtain (group of air curtains) exceeds 4m, then we recommend using an auxiliary bracket:

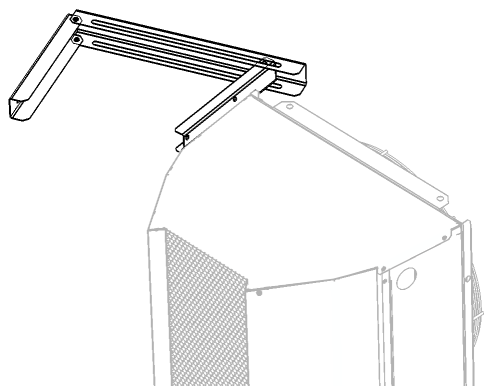

6) The bracket may also serve as a link of 2 air curtains

! Maximum permissible installation height of air curtains is 6.5 m. If you need a greater height, it is necessary to ensure the supporting construction

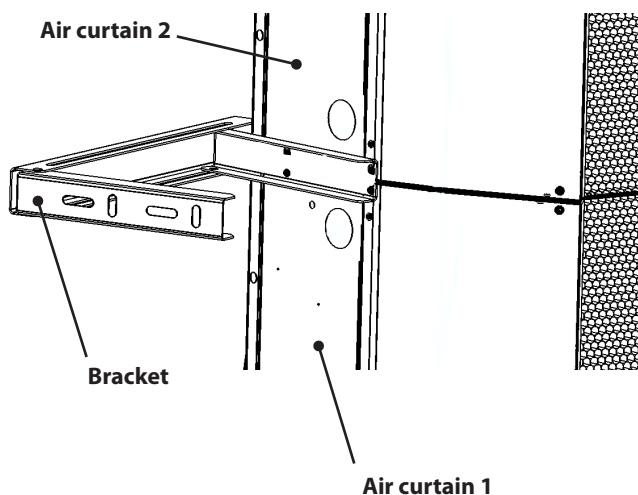

7) Set the required counterblow

! By using a separate bracket you can set potential 10° on each side

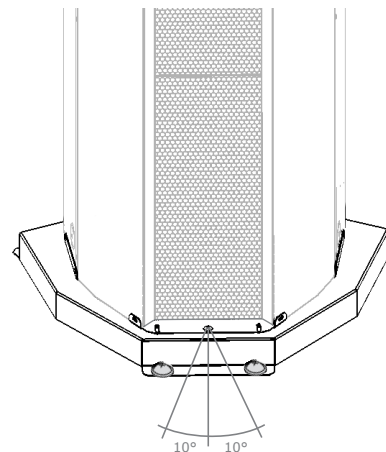

! The setting of the counterblow is very important and influences the effect of screening. The recommended counterblow of the whole air curtain including the base may be in the range 10-40°.

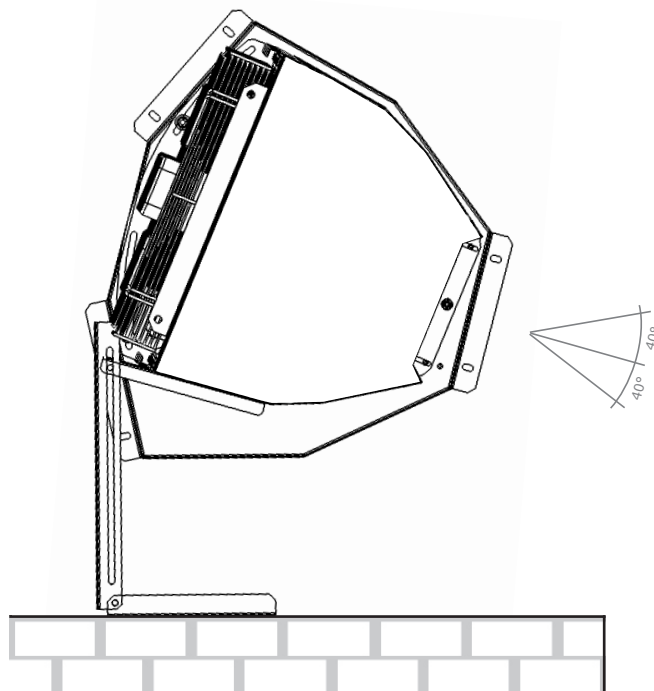

7. INSTALLATION



VERTICAL FIXING OF THE AIR CURTAIN - STATIONARY BRACKET

 Floor brackets are optional accessories of the air curtain and it is necessary to order them.

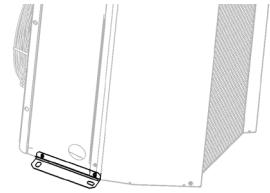

1) Install the brackets on the air curtain

 Fasten by using screws supplied to this base (4 pieces)

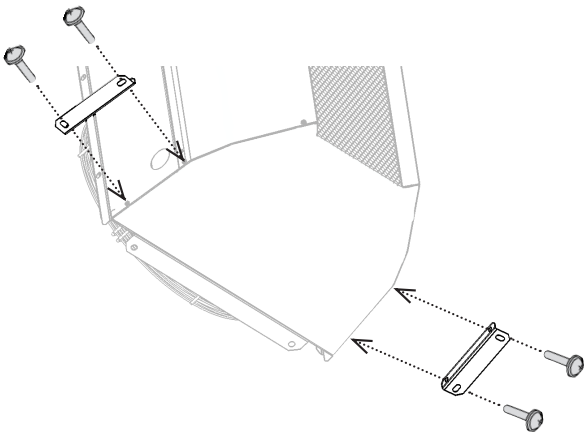

2) Measure the holes by using the holes in the bracket, that you subsequently drill into the floor

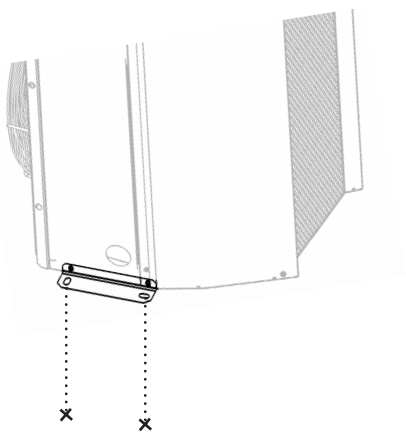

3) Fasten the air curtain to the floor

 The installation material is not part of the air curtain. Ensure a good quality material with respect to the installation place.

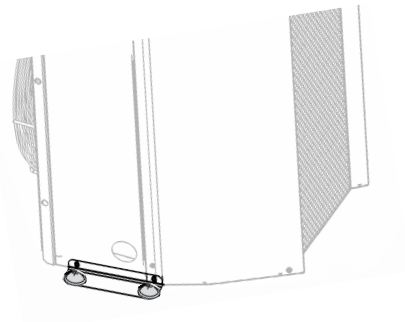
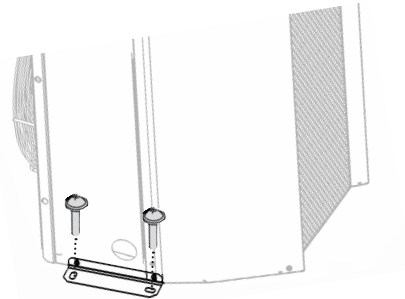

7. INSTALLATION

VERTICAL FIXING OF THE AIR CURTAIN - STATIONARY BRACKET

 Floor brackets are optional accessories of the air curtain and it is necessary to order them.

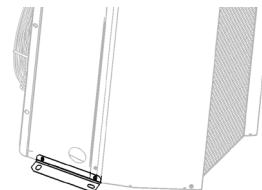

4) If the height of the air curtain (group of air curtains) exceeds 4m, then we recommend using an auxiliary bracket:

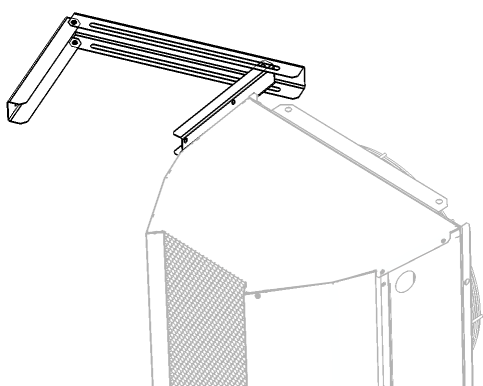

5) The bracket may also serve as a link of 2 air curtains

 The maximum permissible installation height of the air curtains is 6.5 m. If you need a greater height, it is necessary to ensure the supporting construction.

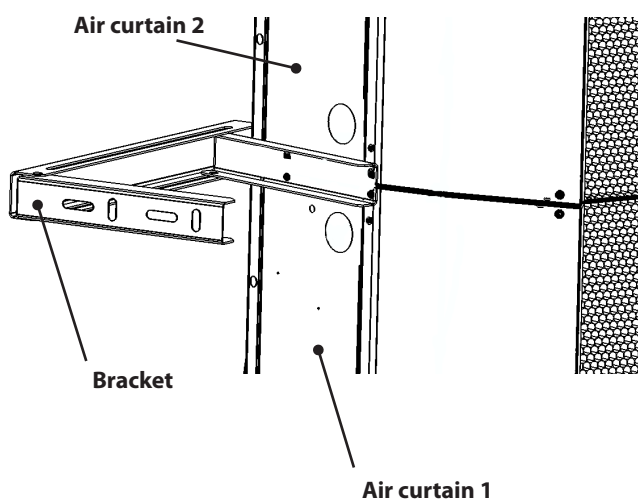

6) Set the required counterblow

 By using a **separate bracket** you can set the potential at 10° on each side

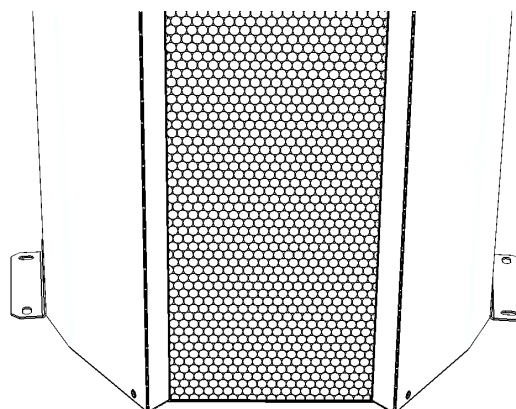

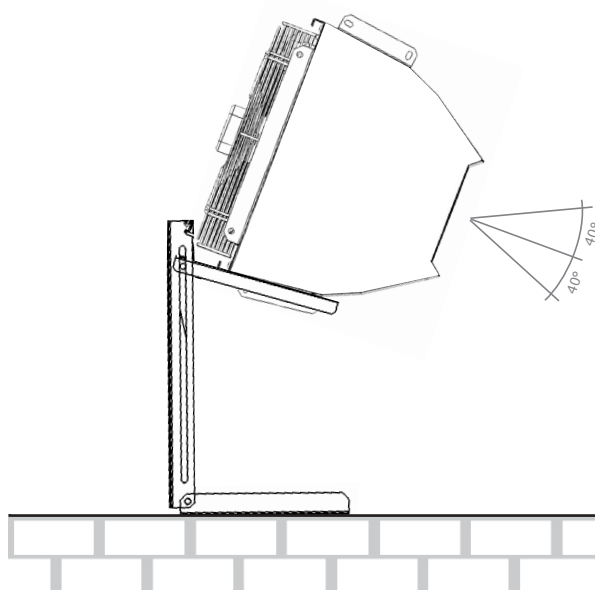

 The setting of the counterblow is very important and influences the effect of screening. The recommended counterblow of the **whole air curtain** may be in the range $10-40^\circ$.





7. INSTALLATION

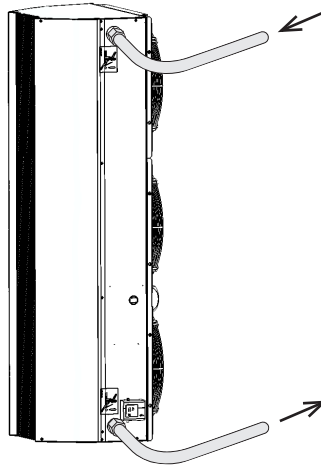

CONNECT HOSEPIPES OF WATER INLET AND OUTLET

-  Flexible hosepipes with connection **G1"**.
-  The connection and pressure tests of the heater must be done by a person with expertise in plumbing and it must meet the applicable standards and regulations of the country.
-  The heat exchanger is designed for water, which may have a **maximum temperature of + 110 °C and a maximum pressure of 1.6 Mpa**. At the inlet and outlet of the water heater it is recommended to install a shut-off valve for the possibility to shut off the water inlet.



-  The exchanger has outlets equipped with an external 1" thread and venting valve (A) and a tube for the placement of a temperature probe (B). Before final use, **make sure that the water exchanger is completely vented**.

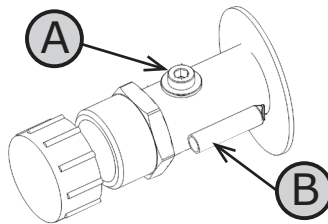

Air curtains labeled **P2** are equipped with an antifreeze protection sensor..

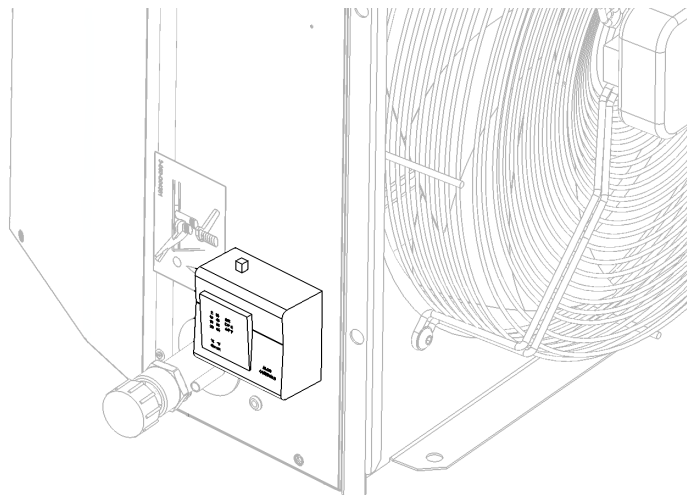

7. INSTALLATION

Regulation of water exchanger by three-way valve ZV-3



The regulation of the water exchanger must be dealt with separately.

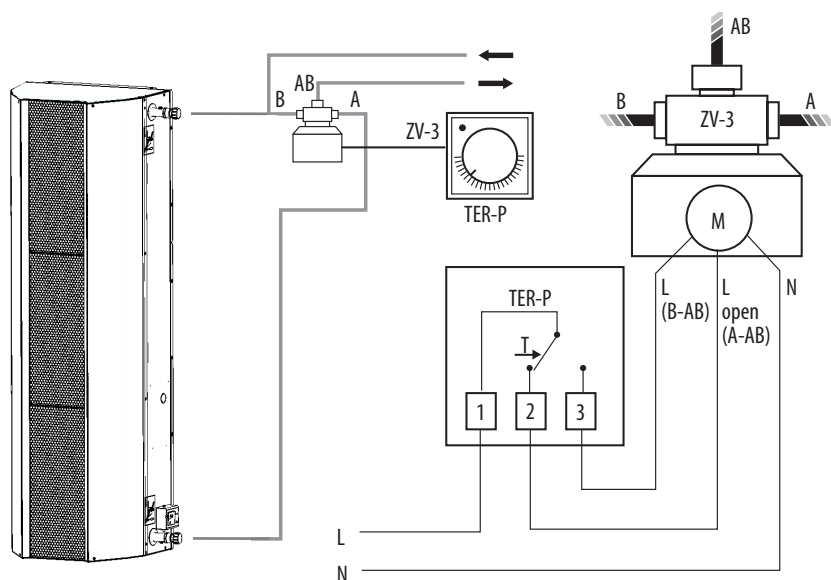

- A detailed description of the regulation of the water exchanger by three-way valve (ZV-3), including its installation can be found in manual to the three-way valve ZV-3.

ELECTRICAL DIAGRAM - ENGINES

AC

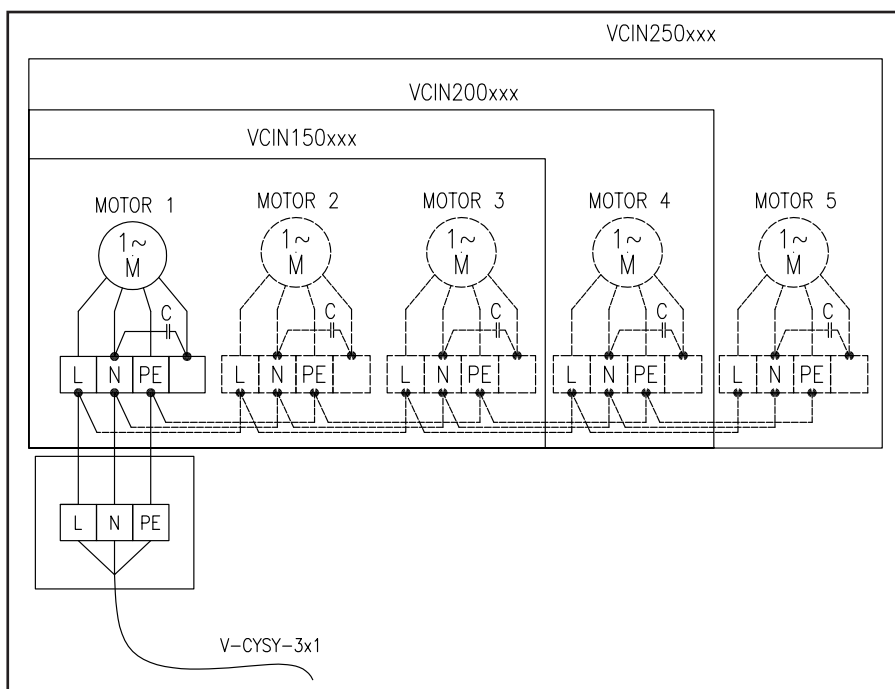

EC

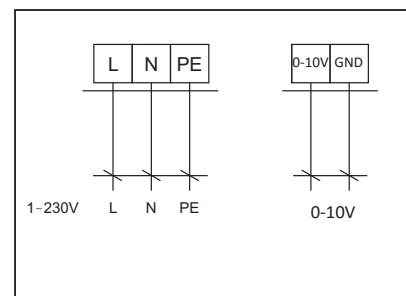

7. INSTALLATION

ELECTRICAL WIRING



- The electrical wiring of the air curtain must be implemented on the basis of a professional project of a qualified electrical designer.
- Installation can be done only by a worker with professional training in electrical engineering. Applicable national regulations and directives must be followed.
- Electrical diagrams on the product take precedence over diagrams in this manual!
- Before installation, make sure that the marking of terminals corresponds to the electrical wiring diagram. If in doubt, contact your supplier and do not connect an air curtain under any circumstances.
- The main power supply must be turned off before any intervention inside the air curtain!
- If the product is connected to any other control system than the original control system, it is necessary that the connection of control and measuring parts was carried out by the company that supplied the system.



- The electrical parameters are shown on the serial label, which is located on the casing of the air curtain.

Marking of the air curtain			
U	= Voltage	I	= Total flow
f	= Frequency	P	= Power
n	= Speed	m	= Weight
ph	= Phase	IP	= IP rating
av	= Air power	ver	=
Serial number			

- The air curtain **must be secured by an appropriate circuit breaker** and according to the **electric parameters of the air curtain!** An oversized fuse is not recommended for safety reasons!
- The main switch that disconnects all poles **of network must be placed in the mains supply.**
- Electrical rating of the air curtain is **IP20 (E1) and IP44 (version S0, V2, P2).**

6.5-1 Power supply of fans

Tabulka počtu ventilátorů ve cloně

Type of air curtain	Fan [ks]	Power	
		AC [V/A]	EC [V/A]
VCIN...150	3	230/3,9	230/4,0
VCIN...200	4	230/5,4	230/5,3
VCIN...250	5	230/6,7	230/6,9

Tabulka minimálního dimenzování napájecích kabelů pro ventilátory

Type of air curtain	Cabel CYSY
	[ks x mm ²]
VCIN...150	3 x 1,0 (Cu)
VCIN...200	3 x 1,0 (Cu)
VCIN...250	3 x 1,0 (Cu)



- The engines of fans are equipped with thermal contacts, which can be used to turn off the air curtain in the event of engine overheating.

7. INSTALLATION

Power supply of electric heater:

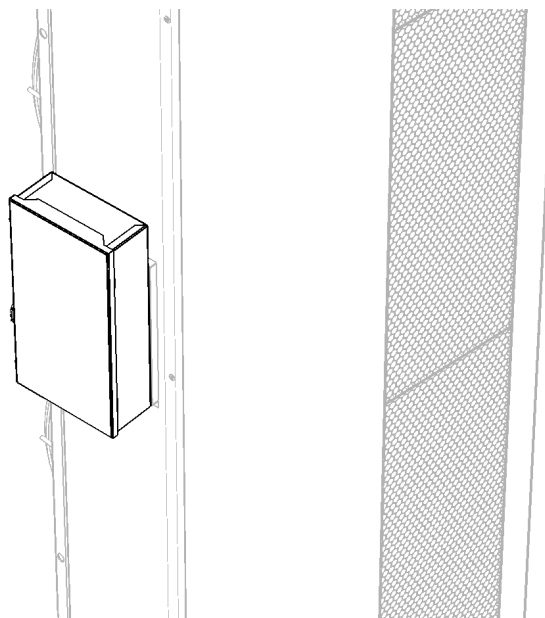
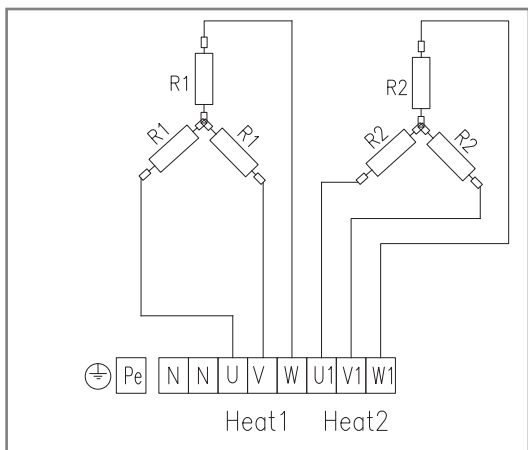

Table of electric heater parametres

Type of the air curtain	Voltage	Electric current
	[V]	[A]
VCIN...150	400	35,2
VCIN...200	400	47,0
VCIN...250	400	58,6

Table of minimal sizing of power cables of heaters

Type of the air curtain	Cabel
	[ks x mm ²]
VCIN...150	4 x 6
VCIN...200	4 x 10
VCIN...250	4 x 10



- Operating and emergency thermostat of the heater is already plugged in such a way that heaters will be disconnected from the power supply in case of overheating. In case of failure of the emergency thermostat, it is necessary to replace the block of heaters because of the use of the melting fuse as protection.

7. INSTALLATION



Installation of the contactor box:

- The contactor box is an optional accessory for the VCIN Type E2. Here's how to install the contactor module:

1) Dismount the electrical box of the electric heater:

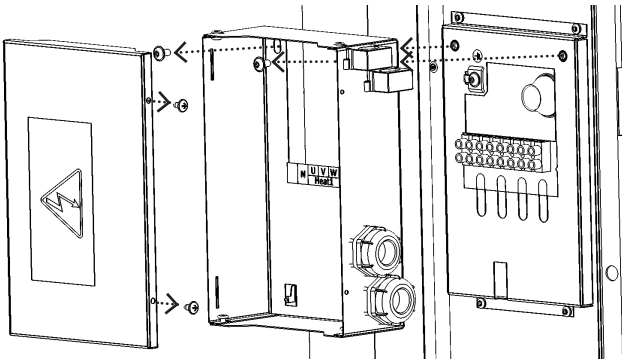

2) Dismount the casing of the contactor module:

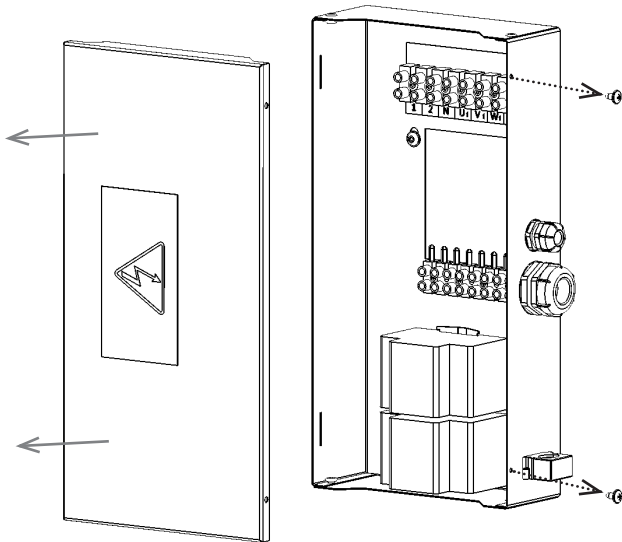

3) Put the contactor module on the screw terminal, screw it and tighten the entire screw terminal properly.

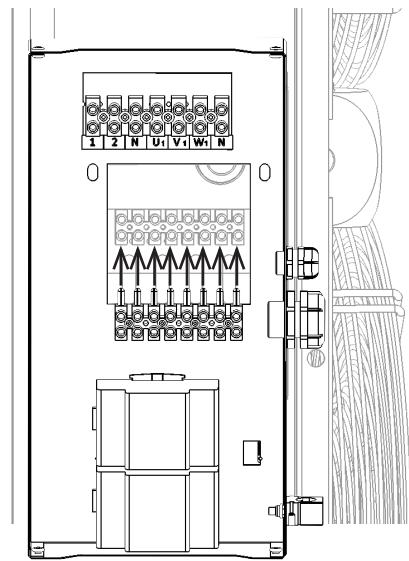

4) Connect according to the diagram and cover it with the box

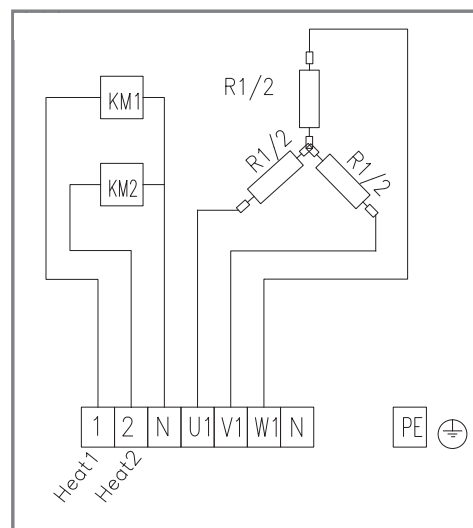

8. FIRST USE



Before putting the air curtain into operation:

- Make sure that any tools or other objects that could damage the air curtain didn't remain in the air curtain.
- Make sure that the electric power supply, regulation and inlet of heating water are properly supplied.
- Make sure that the air curtain is properly covered.
- Become familiar with the instructions of all used components.



Before putting the air curtain into operation, carefully read all the instructions for all components used in the system.



Test the regulation of the fan

- Test the accuracy of the direction of fan rotation
- Test the accuracy of the range of speed regulation
- Test the fan behavior when using external elements

Test the regulation of electric heating

- Test the functionality of the range of the heater's regulation
- Test the behavior of the heater when using external control elements

Test the regulation of water heating

- Test the functionality of the range of the heater's regulation
- Test the behavior of the heater when antifreeze protection is activated
- Test the behavior of the heater when using external control elements

9. MAINTENANCE

Cleaning procedure

 The main electrical power supply (for fan + heater) must be shut down during maintenance of the heating unit. Before maintenance it is necessary to let the air curtain cool down! When handling the unit, it is necessary to use protective gloves against injury by sharp edges!

The following procedure illustrates the cleaning of one section of fans.
Cleaning needs to be done on all the fans.

1) Dismount the section of fans from a casing of the unit

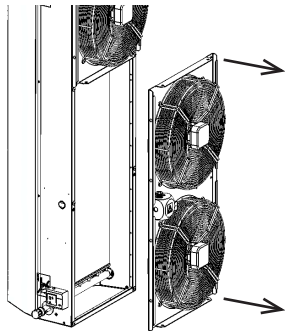

2) Clean the fans on all sides carefully

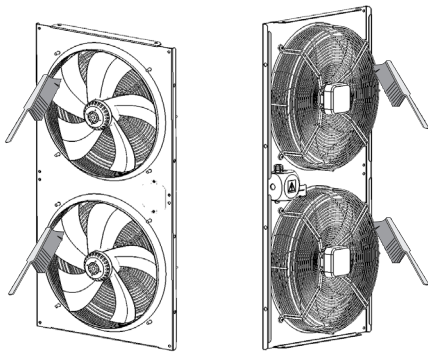

3) Clean the water exchanger (if the air curtain has one)

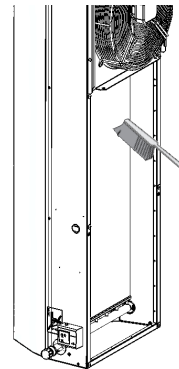

4) Replace the fans back

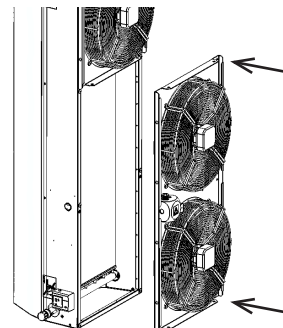

- Compressed air, chemicals, solvents, water, or sharp objects are forbidden to use for cleaning.
- You can clean the water exchanger and the inside of the air curtain with a soft brush or vacuum cleaner.
- For cleaning the unit's casing it is best to use a cloth and soapy water

PERIODIC INSPECTIONS OF THE AIR CURTAIN

It is recommended to perform a periodic inspection of the status of the curtain after every 500 hours of operation, and also before and after the heating season.

- inspection of pollution of the water exchanger
- inspection of the status of the fan (especially the functionality of the fan and bearings)
- leak test of the water exchanger and connections
- inspection of the curtain whether it is damaged in any way (especially fan basket)
- inspection of tightening of screw connections, especially consoles
- inspection of the status of the filter (which may be more frequent due to the installation conditions)

10. TROUBLESHOOTING

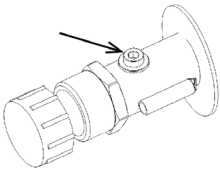
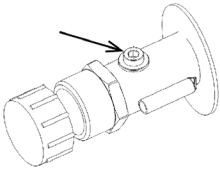

If you are unsure of the correctness of steps, do not attempt to perform any repairs and contact professional service!!!

Behavior of device	Supposed problem	Solution
The device is noisy	Air in the exchanger	Vent the heat exchanger by using the venting screws. 
	Shut-off valves on the device are not fully open.	Open the shut-off valve fully.
	Damaged bearings of the fan. The impeller has its own will, or vice versa it cannot rotate freely.	It is necessary to dismantle and change the fan bearings at an authorized service, or change the entire fan.
	Unbalanced impeller of the fan rotates freely but when you turn it on the fan it vibrates.	Dismantle the fan and take it to professional service for balancing.
Insufficient heating output of the air curtain	Air in the exchanger of the curtain.	Vent the heat exchanger by using the venting screws. 
	The exchanger is very dirty.	Dismantle the fan and clean the exchanger. It is convenient to use hot water or steam to clean. Do not use aggressive detergents.
	Shut-off or control valves on the device are not fully open.	Open the shut-off valves fully, check if the control valve is in the open position.
	Wrong direction of the rotation of the mixing valve.	Repair the electrical wiring in the screw terminal of the regulation.
	Clogged filter (if installed)	Change the filter or clean the filter.
	Thermostat on electric heating rod is open	Check heating elements

If you are unable to discover the defect, remove it or the intervention into the device is required, please contact authorized service!

WHEN YOU AREN'T ABLE TO REMOVE DEFECT BY YOURSELF

If you are unable to resolve the problem, contact the supplier.



For the fast removal of defects please provide the following information:

- product reference number ①
- serial number ②
- running time
- used accessories
- installation location
- installation condition (including electrical)
- detailed description of the problem and the steps that you have taken for its removal

Warranty and post-warranty service is performed by the manufacturer, supplier or authorized service organization. When ordering service intervention it is necessary to describe the defect, product type designation indicated on its label, and the location of installation.

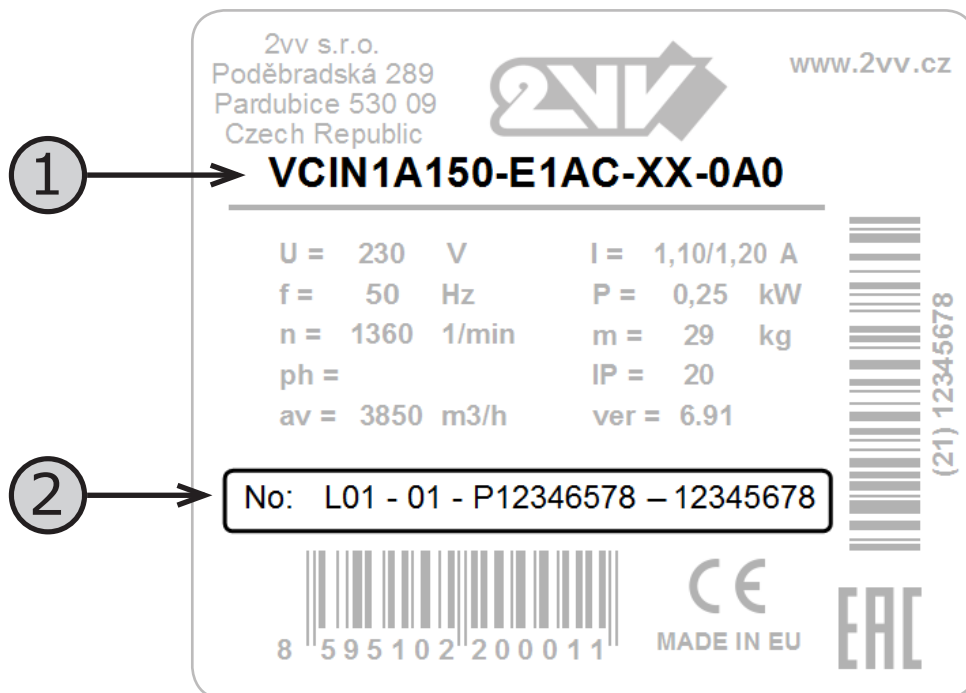



Here stick the label, which you can find in accessories,
for the future problem solving.

Copyright © 2VV
All rights reserved.

**Producer is not liable for damage to equipment caused by improper installation and operation,
which are contrary to the instructions and contrary to common practice in the installation and operation
of air handling units and regulation systems.**