



PARTNER
IN VENTILATION
2VV.CZ

EN

STANDESSE

INSTALLATION

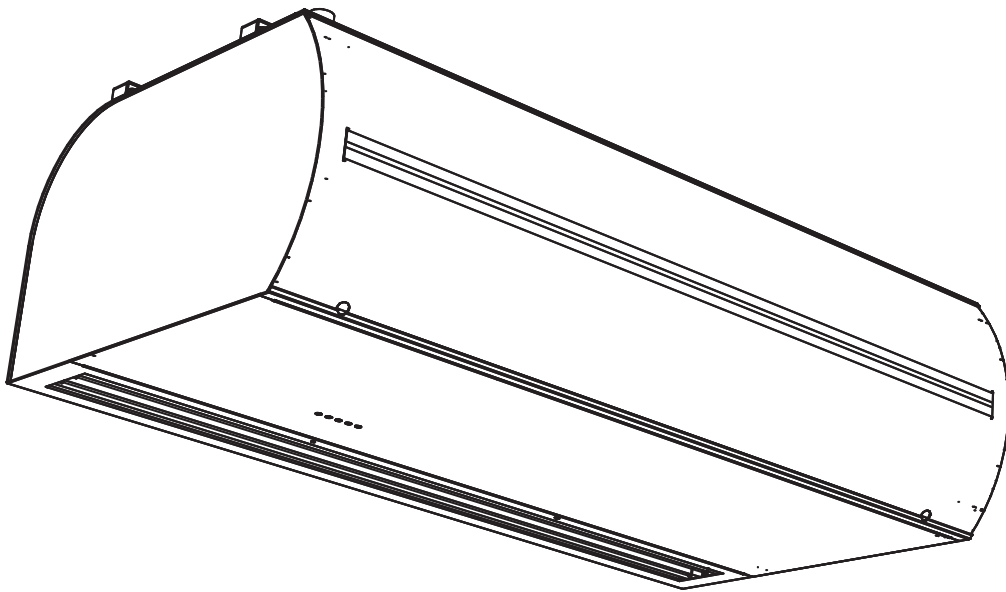





4-118-0256



1. BEFORE YOU BEGIN

Meaning of symbols in the manual:

SYMBOL		MEANING
	ATTENTION!	Warning/caution
	DO NOT OVERLOOK!	Important instructions
	YOU WILL NEED NOTE	Practical tips and information
	TECHNICAL INFORMATION	More detailed technical information
	LINK	Refer to other parts/sections of the manual



Before installation, thoroughly read the section “Safe use of air curtains”. It contains all instructions on the safe and correct use of the product.

This manual contains important instructions to ensure correct installation of the air curtain. Before installation, read all of the following instructions thoroughly and then adhere to them! The manufacturer reserves the right to make changes, including to technical documentation without prior notice. Save this user manual for further use. The instructions in this manual are a part of the product.

Statement of compliance

You will find the details at the www.2vv.cz website

2. UNPACKING

2.1 CHECK THE SHIPMENT

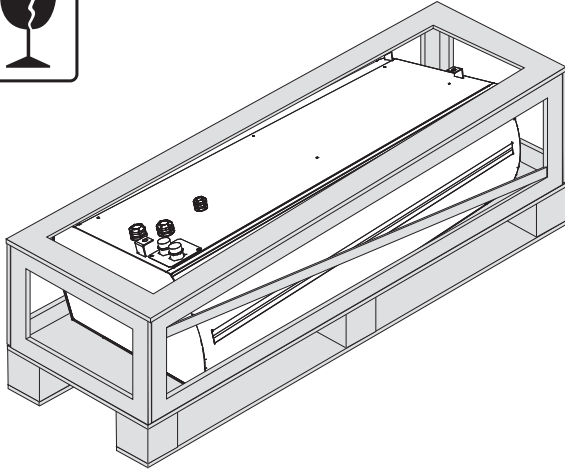

- After delivery, immediately check to see if the packaged product is damaged. If the packaging is damaged contact the delivery service. If the complaint is not filed in time, your claim may not be valid later.
- Check to see if it is the same product you ordered. If there are any discrepancies, do not unpack the curtain, and immediately report the defect to the supplier.
- After unpacking, check to see if the curtain and other parts are in order. If you have any doubts, contact the supplier.
- Never install a damaged air curtain!
- If you do not unpack the curtain immediately after delivery, it must be stored in a dry indoor environment with an ambient temperature between **+5 °C and +40 °C**

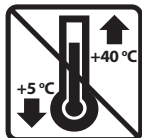

2.2 UNPACK THE AIR CURTAIN

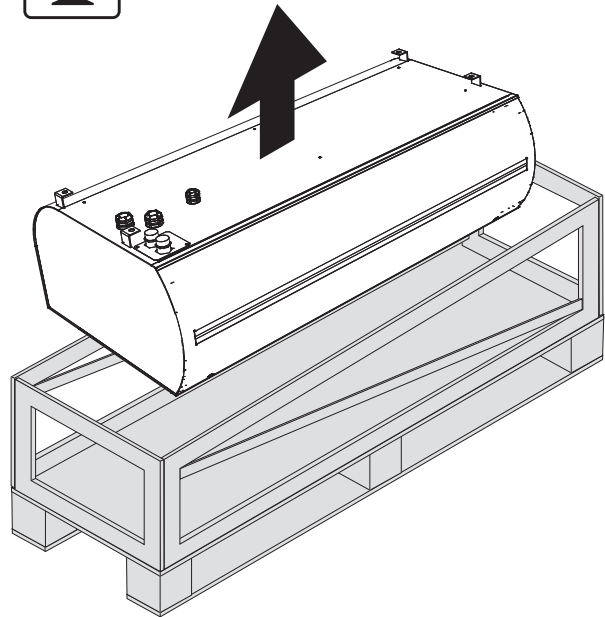

- If the curtain has been transported at temperatures below 0° C, it will be necessary to let it sit for at least 2 hours under normal operating conditions after unpacking, without turning it on. This will allow the air curtain's interior temperature to stabilise.

	<p>All used packaging materials are environmentally friendly and may be reused or recycled. Take an active part in environmental protection and see that packaging materials are correctly disposed of or repurposed.</p>	
--	---	--

3. MAIN PARTS

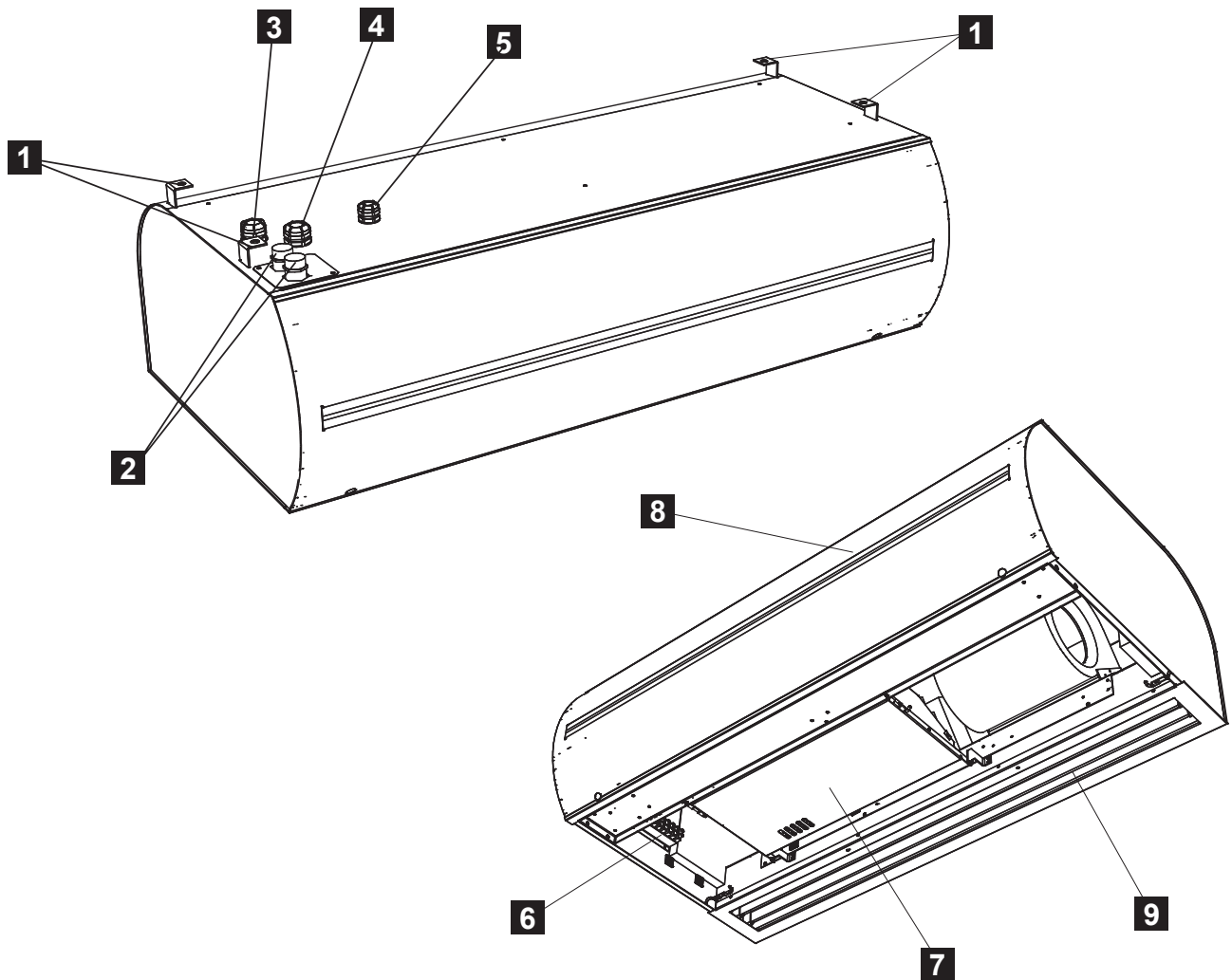

1. Suspension holders
2. Water coil connection $\frac{3}{4}$ "
3. Power supply cable plug
4. Control cable plug (BASIC control module) or cable plug for water coil regulator (COMFORT,SUPERIOR control modules)
5. Pit for capillary TV1/1
6. Power supply connectors and fusse location
7. Control modul socket
8. Inlet face cover
9. Outlet grid

4. DIMENSIONS

Air curtain dimensions

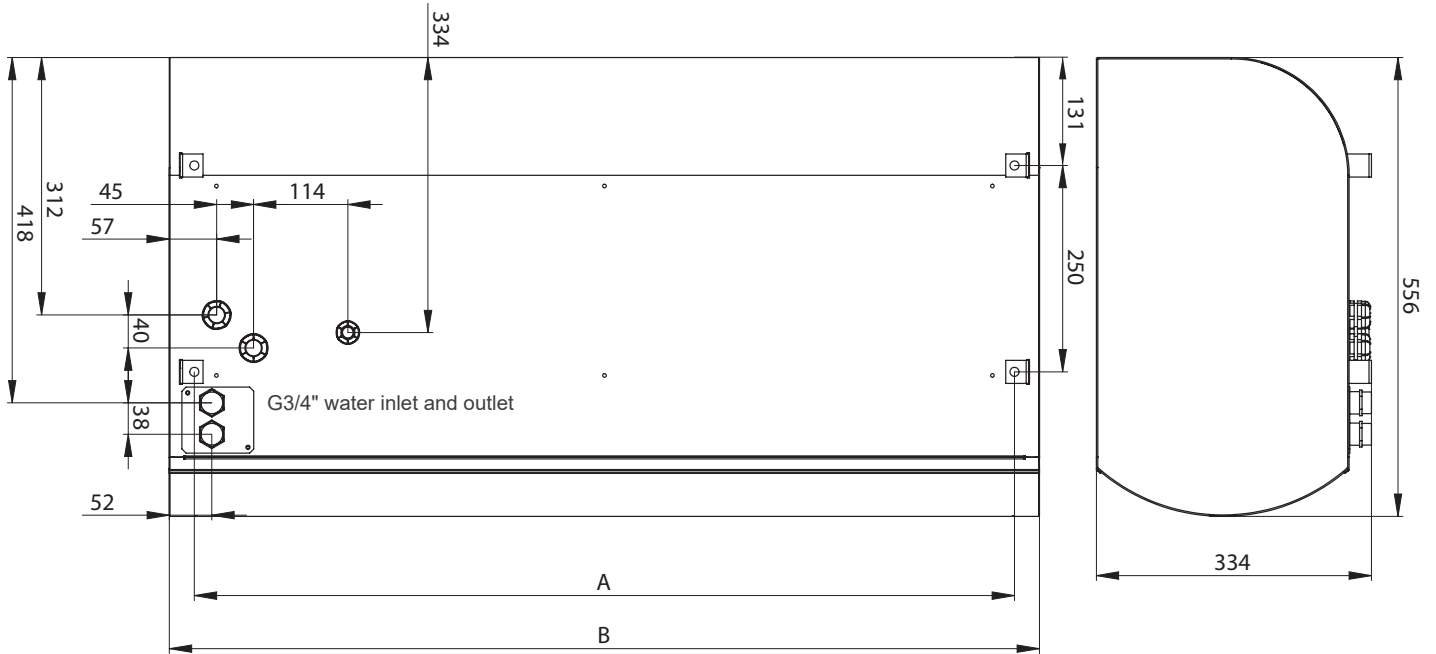

Type	Spacing of installation holes A [mm]	Width B [mm]
VCS4x-10x-x..	994	1054
VCS4x-15x-x..	1494	1554
VCS4x-20x-x..	1994	2054
VCS4x-25x-x..	2394	2454

5. TECHNICAL PARAMETERS

Air curtain type	Recommended installation height [m]* 1)	Air capacity [m ³ /h] 1)			Noise** [dB(A)] 1)			Heater power [kW]	Heater voltage/current [V/A]	Fan voltage/current [V/A]	Weight [kg]
		3rd level	2nd level	1st level	3rd level	2nd level	1st level				
VCS4B-10S-	4,0	1626	1182	813	56,0	47,9	39,8	-	-	230/2,25	42
VCS4B-15S-		2513	1774	1256	58,7	50,9	43,2	-	-	230/3,50	59
VCS4B-20S-		3362	2328	1626	59,7	51,8	43,8	-	-	230/4,70	76
VCS4B-25S-		4065	2956	2106	60,8	53,4	44,8	-	-	230/5,60	93
VCS4B-10E-		1589	1145	813	56,0	47,9	39,8	9,5	400/13,7	230/2,25	46
VCS4B-15E-		2476	1700	1219	58,7	50,9	43,2	15	400/21,7	230/3,50	63
VCS4B-20E-		3362	2291	1589	59,7	51,8	43,8	19	400/27,5	230/4,70	81
VCS4B-25E-		3991	2919	2069	60,8	53,4	44,8	24,5	400/35,4	230/5,60	99
VCS4B-10V-		1552	1109	776	55,8	47,9	39,7	16,97	-	230/2,25	48
VCS4B-15V-		2439	1663	1182	57,6	49,4	41,6	38,47	-	230/3,50	65
VCS4B-20V-		3252	2180	1552	59,3	51,0	42,9	52,64	-	230/4,70	83
VCS4B-25V-		3880	2734	1884	60,6	52,7	45,4	65,46	-	230/5,60	97
VCS4C-10S-	5,0	2303	1656	1172	59,6	51,7	43,6	-	-	230/3,30	48
VCS4C-15S-		3353	2424	1737	60,0	52,1	44,2	-	-	230/4,60	64
VCS4C-20S-		4161	2990	2101	60,3	52,6	44,5	-	-	230/5,55	80
VCS4C-25S-		5090	3636	2666	61,1	53,4	45,6	-	-	230/6,90	98
VCS4C-10E-		2262	1616	1131	59,6	51,7	43,6	9,5	400/13,7	230/3,30	53
VCS4C-15E-		3272	2384	1697	60,0	52,1	44,2	15	400/21,7	230/4,60	68
VCS4C-20E-		4080	2949	2060	60,3	52,6	44,5	19	400/27,5	230/5,55	86
VCS4C-25E-		4888	3555	2586	61,1	53,4	45,6	24,5	400/35,4	230/6,90	110
VCS4C-10V-		2222	1576	1115	59,1	51,4	42,9	20,80	-	230/3,30	55
VCS4C-15V-		3151	2182	1616	59,7	52,2	43,9	43,87	-	230/4,60	70
VCS4C-20V-		3878	2788	1939	60,2	52,6	44,8	56,21	-	230/5,55	88
VCS4C-25V-		4808	3434	2424	60,7	53,3	45,5	72,12	-	230/6,90	108

Suction air temperature +18°C, at maximum heating level and highest fan speed.

Other technical parameters please see the relevant technical list product



6. INSTALLATION

5.1 CHOOSE THE INSTALLATION SITE AND INSTALL THE AIR CURTAIN

5.1-1 Built up dimensions

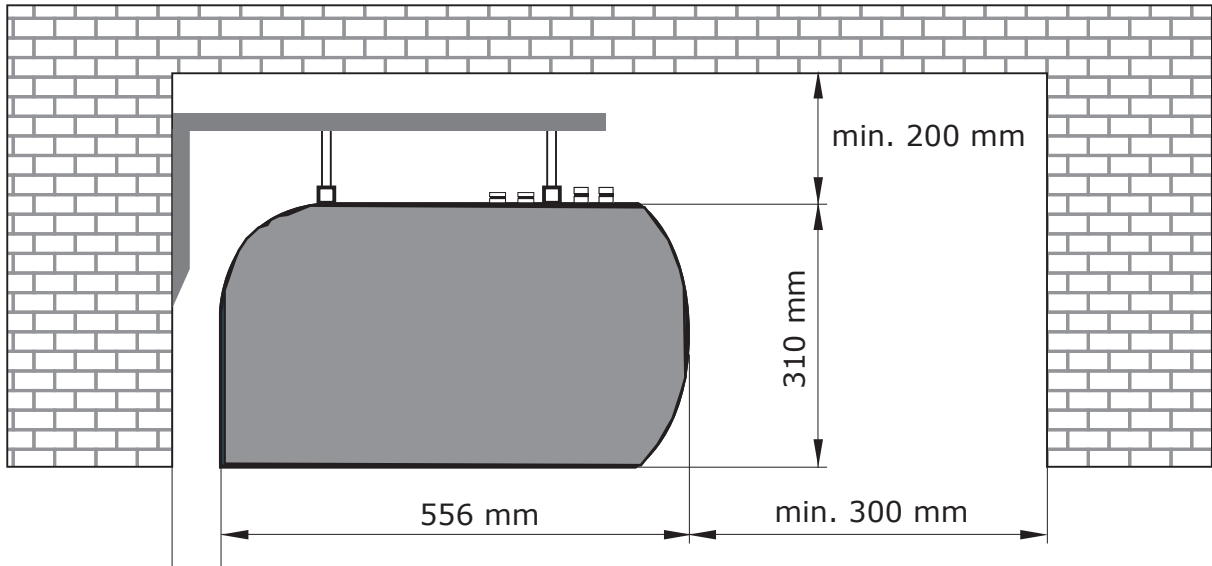

- The air curtain must be installed only in a horizontal position!
- The curtain can be installed over the door opening. All separation distances for flammable materials and safe use of air curtain has to be kept.
- The installed position of the air curtain can be chosen to accommodate the service hood.
- It must be operated in dry, covered indoor spaces with an ambient temperature between +5° C and +40° C and relative humidity up to 80%
- The air curtain is not intended for moving air that contains combustible or explosive mixtures, chemical fumes, coarse dust, soot, grease, poisons, infectious germs, etc.

5.1.-2 Clearance distance

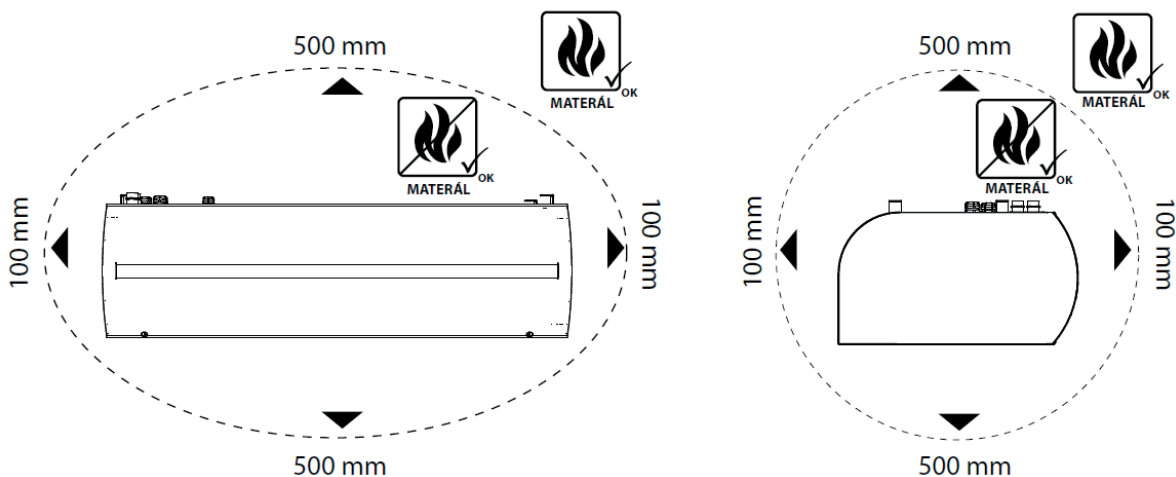

●● 6. INSTALLATION

5.1-3 Measure the installation site

- Only nonflammable materials (those that do not burn, smoulder or carbonise) or fire-resistant materials (those that do not burn, but mainly smoulder, e.g., plaster board) can be kept within 100 mm in any direction of the air curtain. However, these materials should not block the intake or outlet openings.
- For air curtains with an electric heater, safe distances from building structural surfaces and flammable objects are as follows:
- The safe distance for flammable materials in the direction of the main air flow (i.e., behind the outlet) is 500 mm,
- The safe distance for flammable materials above the air curtain is 500 mm,
- The safe distance for flammable materials in other directions is 100 mm.

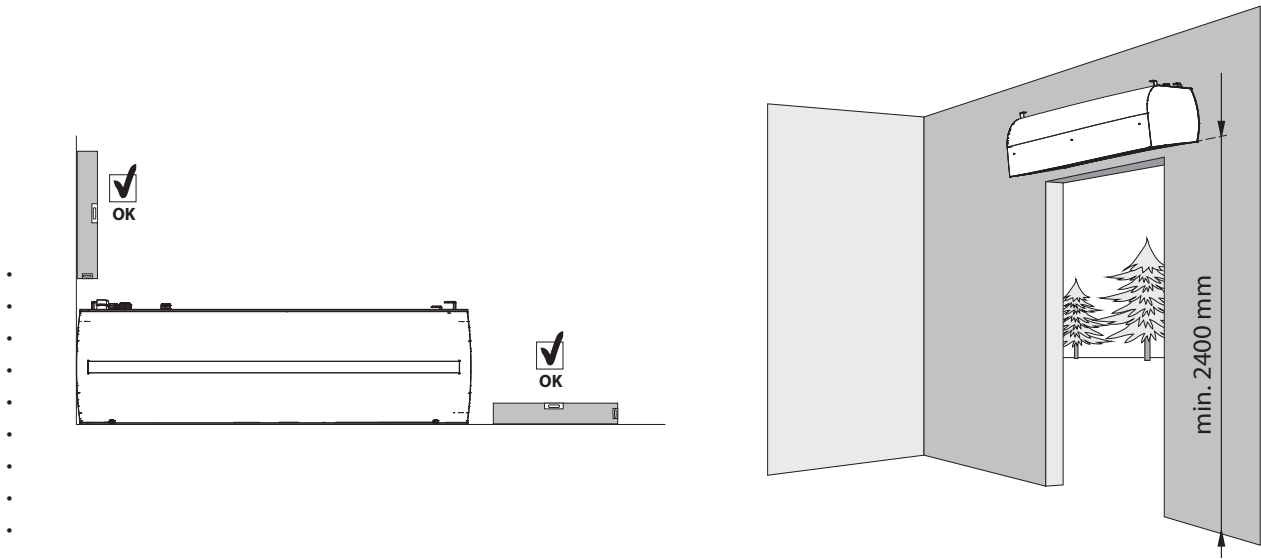

6.1-3 Measure the installation site

Choose the location for the installation and measure the installation site. Measure out the dimensions of ceiling installation or for wall mounted brackets.

6. INSTALLATION



For wall installation use „Wall mounted bracket set“: VCS4-KONZ-STE. „Wall mounted bracket SET“ has to be ordered separately as an optional accessory.

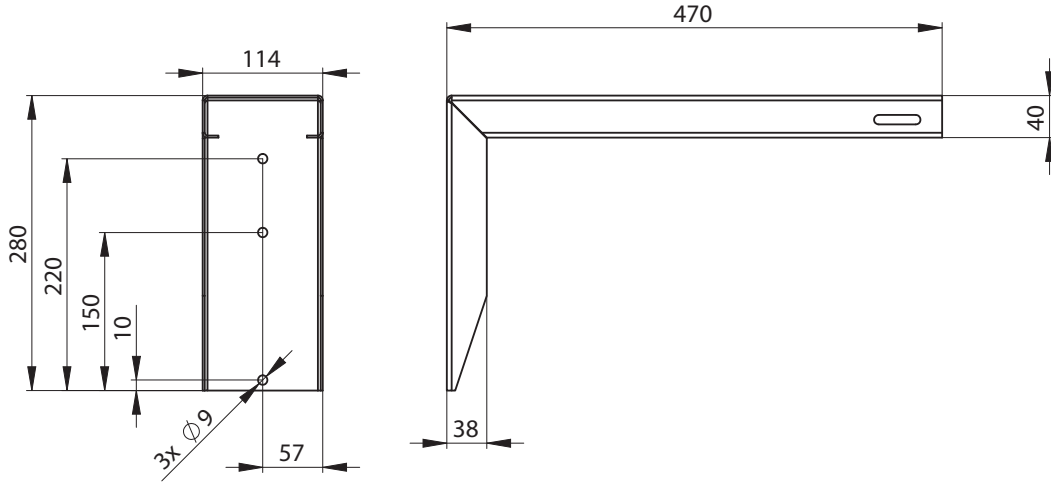

Measurement

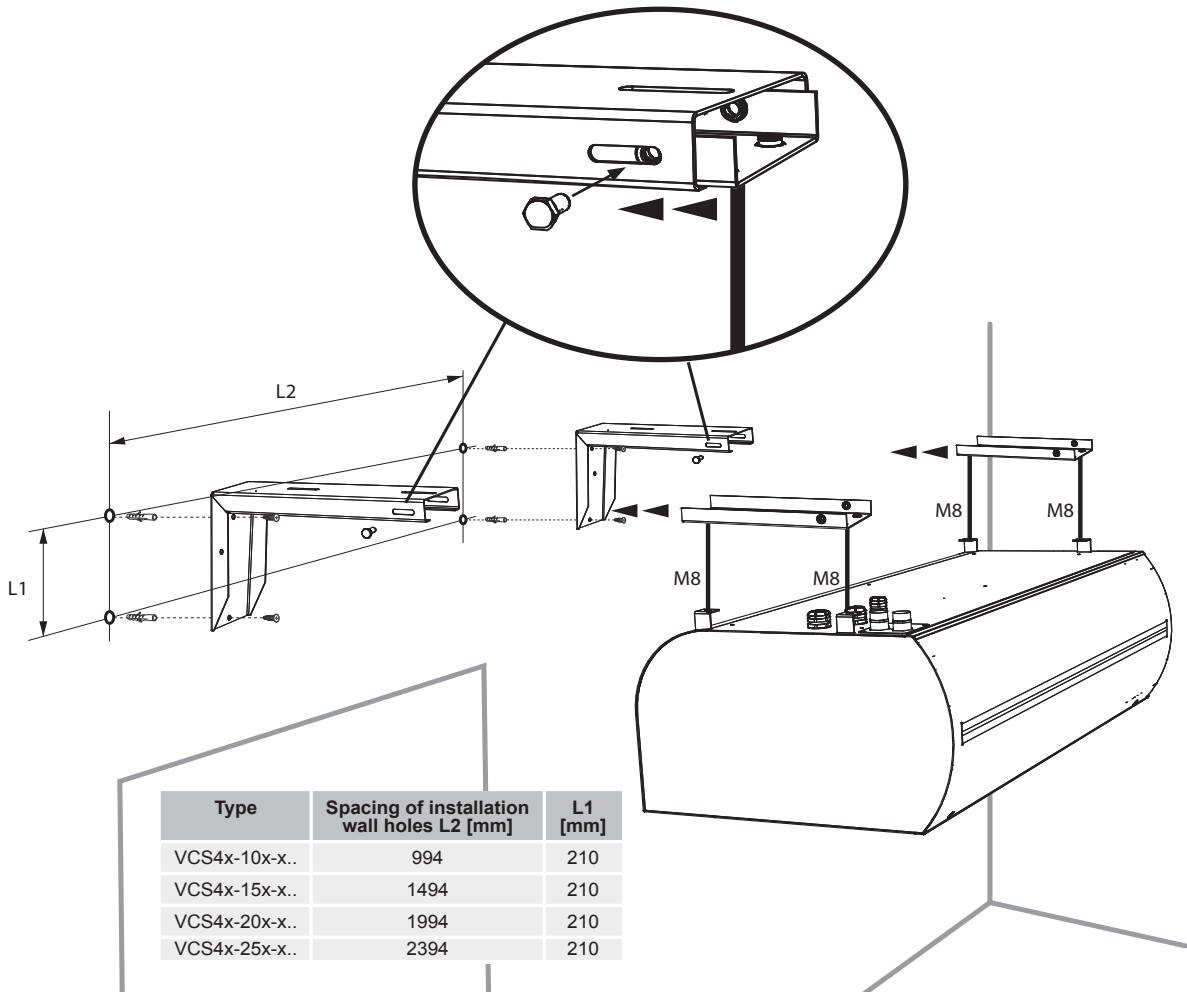

● ● 6. INSTALLATION

For ceiling installation use „Ceiling holder SET“: VCS4-KONZ-STR. „Ceiling holder SET“ has to be ordered separately as an optional accessory.

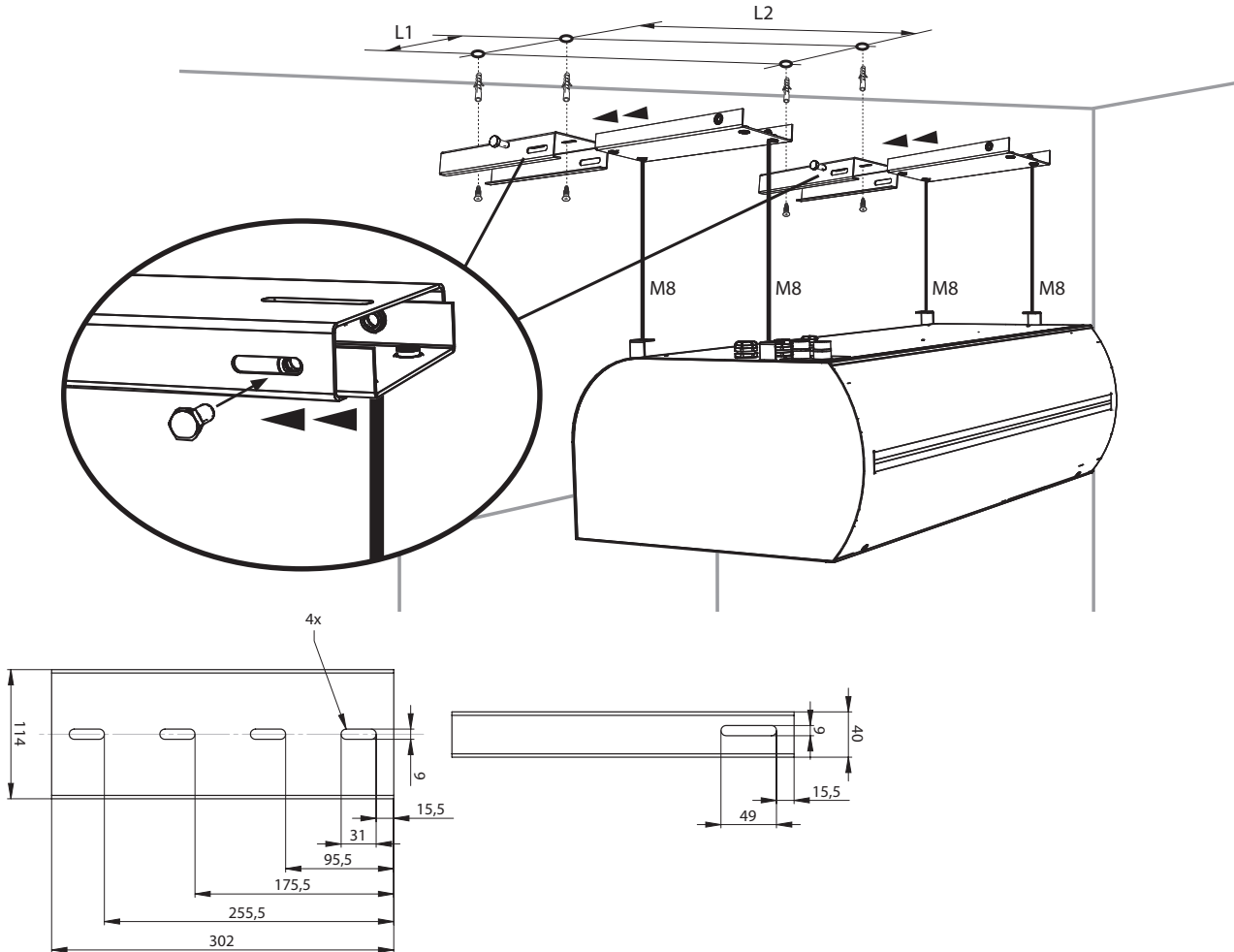

Type	L1 [mm]	L2 [mm]
VCS4-X-100-X...	240	994
VCS4-X-150-X...	240	1494
VCS4-X-200-X...	240	1994
VCS4-X-250-X...	240	2394

5.1-4 Suspend the air curtain on the threaded bars and ensure that the suspension will not come loose



- In consideration of the air curtain weight into account, it is necessary to use either a suitable lifting device (forklift, etc.) or use two additional individuals to support it, as long as it is not securely fastened.



- Suspension has to carry the weight of the air curtain!

● ● 6. INSTALLATION

5.2 CONNECT THE WATER INTAKE AND OUTLET HOSES

VCS4-x-xxx-V(W)-...



- A flexible hoses with a G3/4" connection



- Connection and pressure testing of the heater must be carried out by a person with professional plumbing knowledge, who must observe current standards and regulations of the given country.
- The maximum water temperature is +100° C. The maximum pressure is 1.6 MPa. We recommend installing a stop valve on the intake and outlet of the heater to allow the water supply to be shut off.

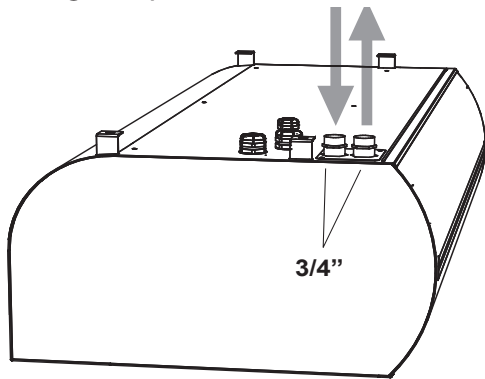

5.2-1 Regulating the water coil with a thermostatic valve TV1/1 (Air curtains with water coil and BASIC control module: VCS-R2-BA-V-xx)

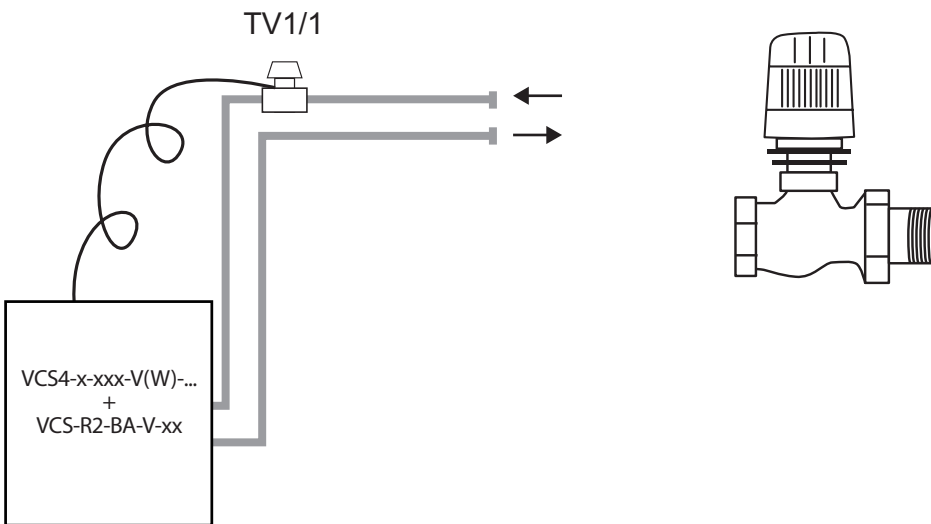

Thermostatic valve TV1/1 is an required accessorie for control module VCS-R2-BA-V-xx



Detailed description of water coil regulation by thermostatic valve (TV1/1), including it's connection, refer the instruction manual for thermostatic valve TV1/1.

6. INSTALLATION

5.2-2 Regulating the water coil with a ZV-3 or RT zone valve (Air curtains with water coil and COMFORT control module: VCS-R4-CO-V-xx)



Zone valve ZV-3 is an required accessorie for control module VCS-R4-CO-V-xx

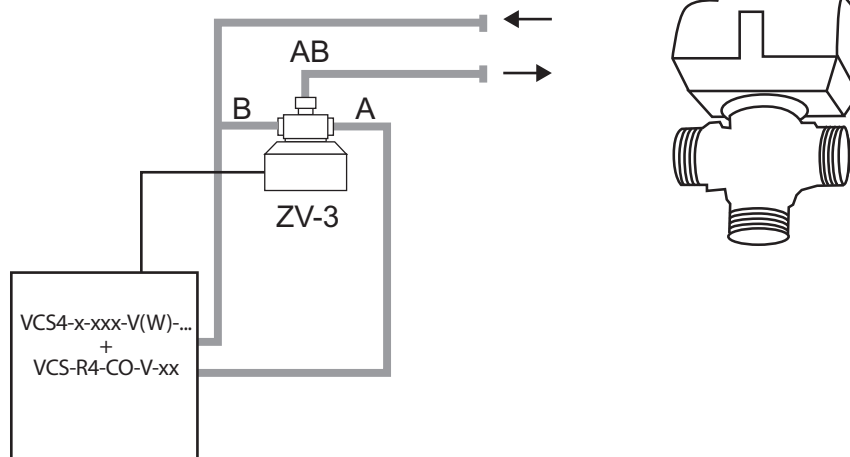

- Detailed description of water coil regulation by zone valve (ZV-3), including it's connection, refer the instruction manual for zone valve ZV-3.



Zone valve RT is an required accessorie for control module VCS-R4-CO-V-xx

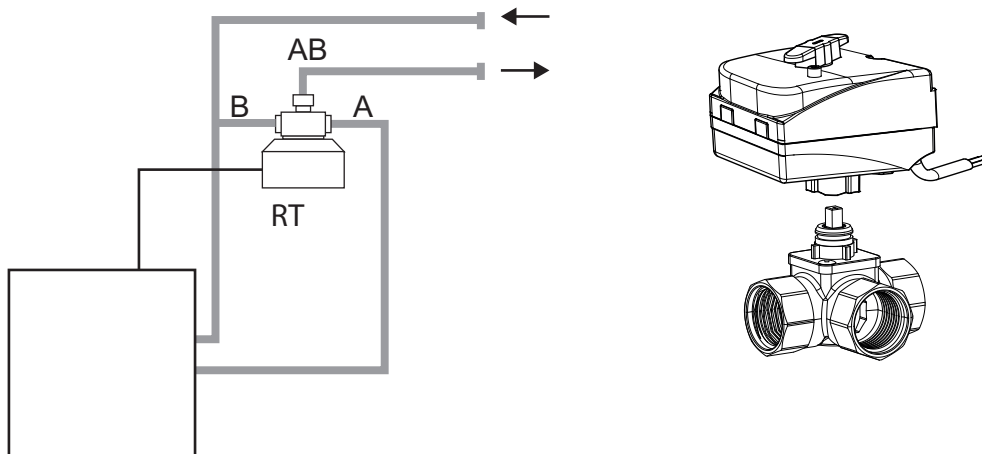

- Detailed description of water coil regulation by zone valve (RT), including it's connection, refer the instruction manual for zone valve RT.

6. INSTALLATION



5.2-3 Regulating the water coil with an zone valve ZV-3-24V (Air curtains with water coil and SUPERIOR control module: VCS-R4-SU-V-xx)



Zone valve ZV-3-24V is an required accessorie for control module VCS-R4-SU-V-xx
24V output is not on regulation

VCS4-x-xxx-V(W)-...
 +
 VCS-R4-SU-V-xx

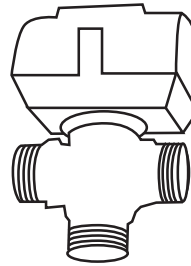
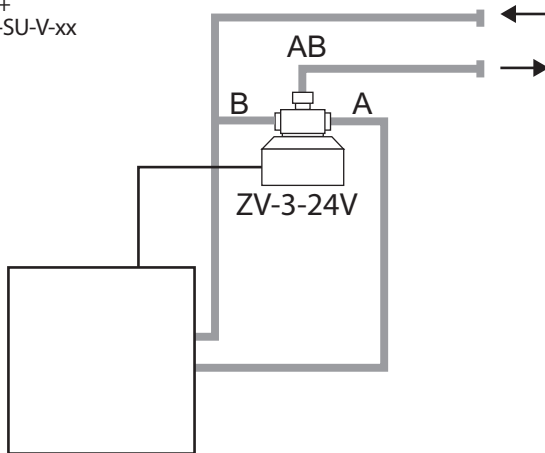

- Detailed description of water coil regulation by zone valve (ZV-3-24V), including it's connection, refer the instruction manual for zone valve ZV-3-24V.

6. INSTALLATION

5.4 ELECTRO INSTALLATION



- The air curtain's electrical connection must be based on a professional design by a qualified electrical systems engineer.
- Installation must be carried out by a professionally trained electrical worker. All applicable national regulations and directives must be observed.
- The electrical schematics on the product take priority over those presented in this manual!
- Prior to installation, check to see if the terminal markings correspond to the markings on the electrical connections diagram. When in doubt, contact your supplier and do not connect the air curtain under any circumstances.
- Never reach inside the air curtain unless the main electrical supply has been turned off!
- If the product is connected to any control system other than the original one, the regulation and measurement components must be connected by the company that supplied the system.
- The electrical contractor defines the minimum size of the feed cable according to the standards applicable at the place of installation, the location for installing the cable, the surrounding conditions, and the curtain's technical parameters.



- **Special attention should be paid to the capacity of the distribution network of the air curtain with electric heater in terms of the supply of the appropriate phase current values for limiting the voltage fluctuations and flickering in the network.**

Minimal cable dimensions:

Type	Cable dimension
VCS4-x-xxx-S...	3Cx1,5
VCS4-x-xxx-V...	3Cx1,5
VCS4-x-xxx-W...	3Cx1,5
VCS4-x-100-E...	5Cx2,5
VCS4-x-150-E...	5Cx4
VCS4-x-200-E...	5Cx6
VCS4-x-250-E...	5Cx10

Fuse motors:

VCS4-x-xxx...		x	
		B	C
xxx	100	3,15A	5A
	150	4A	6,3A
	200	6,3A	8A
	250	8A	12A

6. INSTALLATION

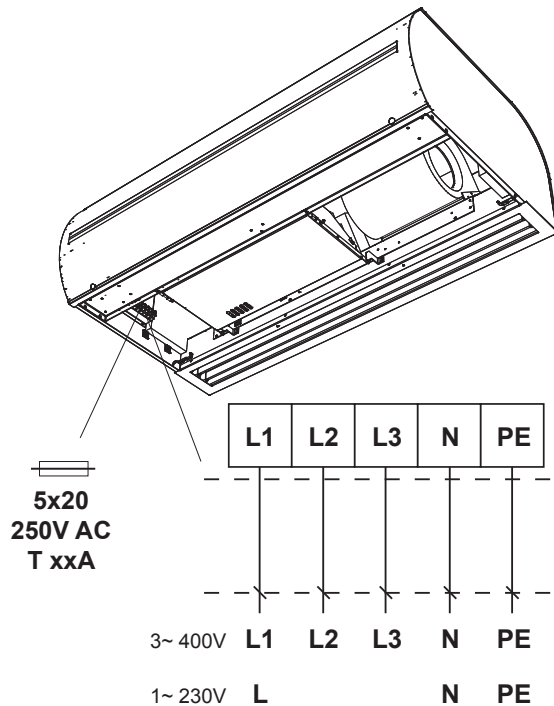

- The electrical parameters are shown on the manufacturer's label, which is located under the air curtain's service cover.

Air curtain Type	
U = Voltage	I = Net current
f = Frequency	P = Output
n = Speed	m = Weight
ph = Phase	IP = IP rating
av = Air output	ver =
Serial number	

- The air curtain must be protected by an appropriate circuit breaker, in accordance with its electrical parameters. For safety reasons, over-designed protection is not recommended.
- The air curtain must be connected using the TN-S system, which means that the neutral conductor must always be connected.
- A main cut-off switch must be placed in the electrical supply network, disconnecting all poles of the network.
- The electrical enclosure of the air curtain is IP 20.



FINESSE air curtains are equipped with a fuse (with T characteristic – slow-blow). This safety fuse protects the electronic panel and fans. It is located under the service cover next to the main power supply connectors.

5.5 CONTROL MODULES

Air curtains FINESSE are produced with universal connection interface. Air curtains FINESSE can be controlled by one of following control modules. Control modules are required accessories and has to be orderot separately. Air curtain is connected with control module by „Quick connection sockets“

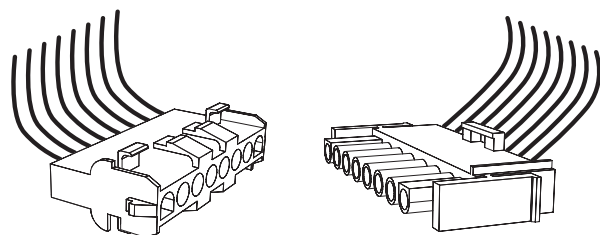

6. INSTALLATION

5.6 INSERT CONTROL MODULE TO THE AIR CURTAIN

1

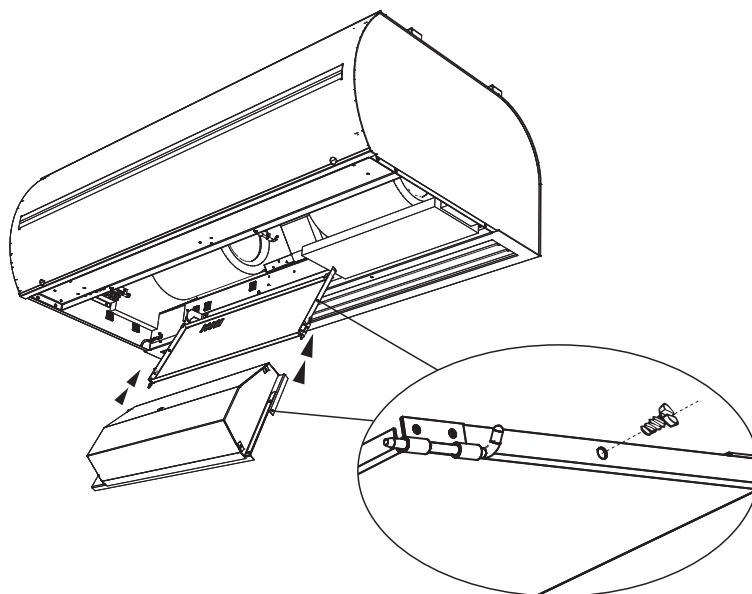

2

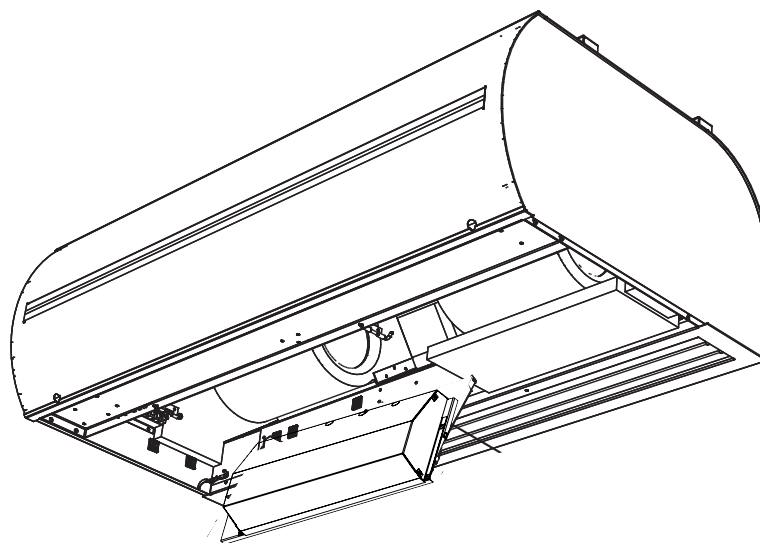

6. INSTALLATION

Connection to the regulation control panel and accessories

3

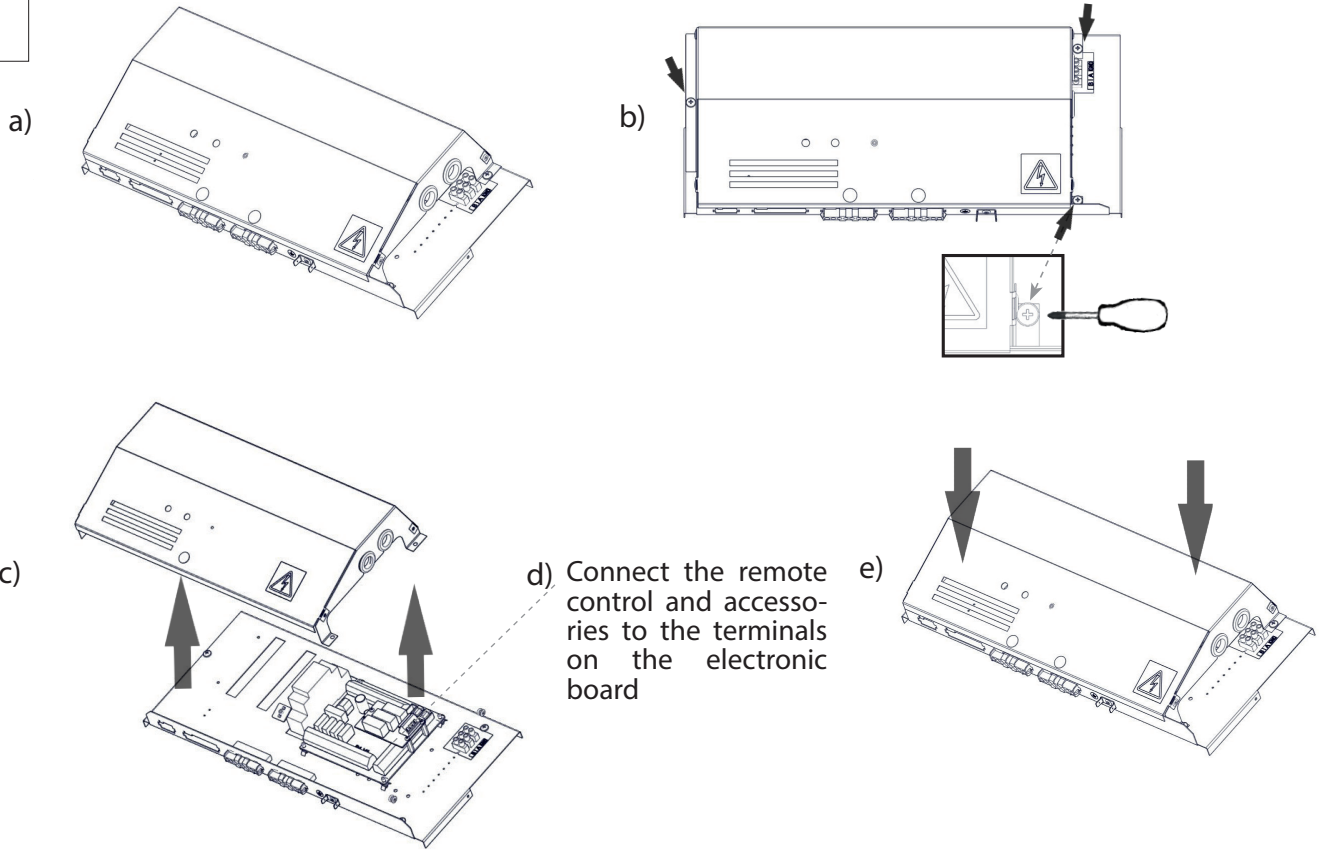

4

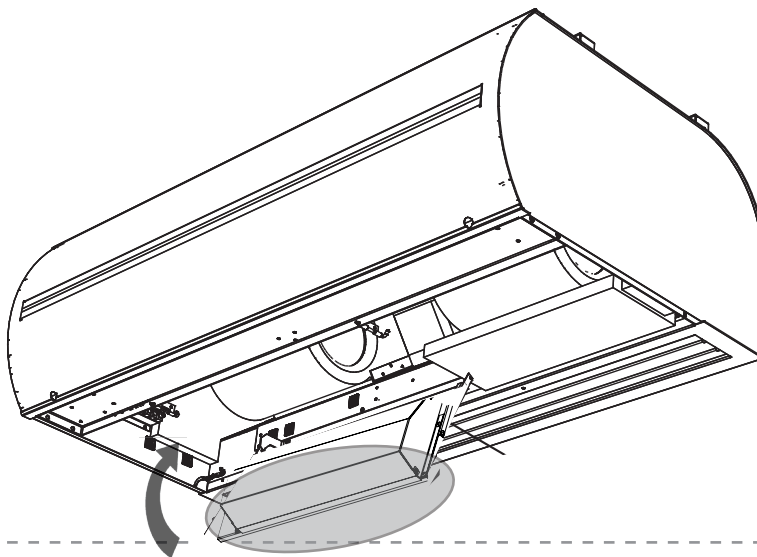

6. INSTALLATION

5.7 EXIT SIGN



- Exit sign marking of emergency exit

For all types of VCS4x- air curtains!



Not included in delivery.

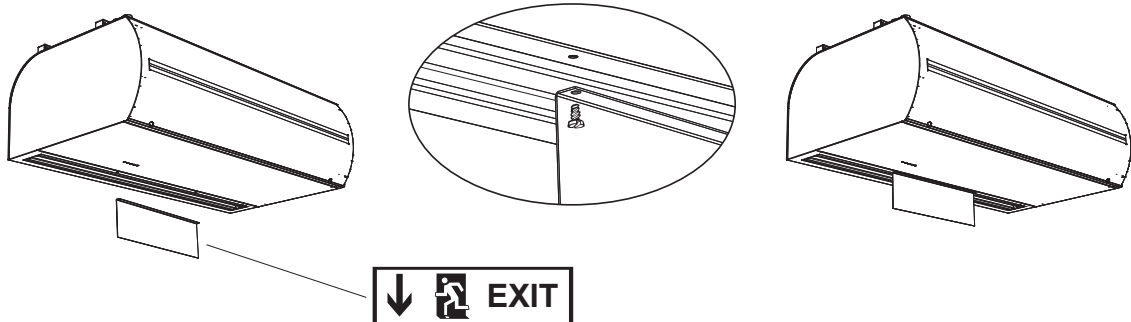

5.8 COVERING THE AIR CURTAIN

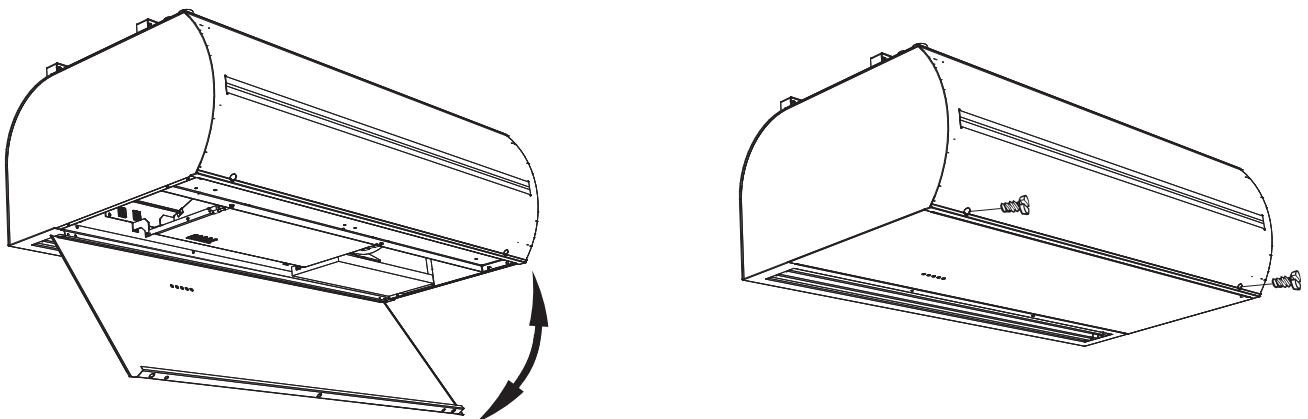

6. INITIAL START-UP



Before starting up the unit check that:

- No tools or other objects that may damage the unit have been left inside.
- The power and heating water supply are well connected.
- The unit is properly covered.
- The control panel is properly connected



During the commissioning, check the proper function of the unit (fans, heating). Check the other possible settings and functions according to the user manual of each regulator

6.1 SET AIR FLOW DIRECTION

This is set by tilting the air curtain's fan louvers in the desired direction.

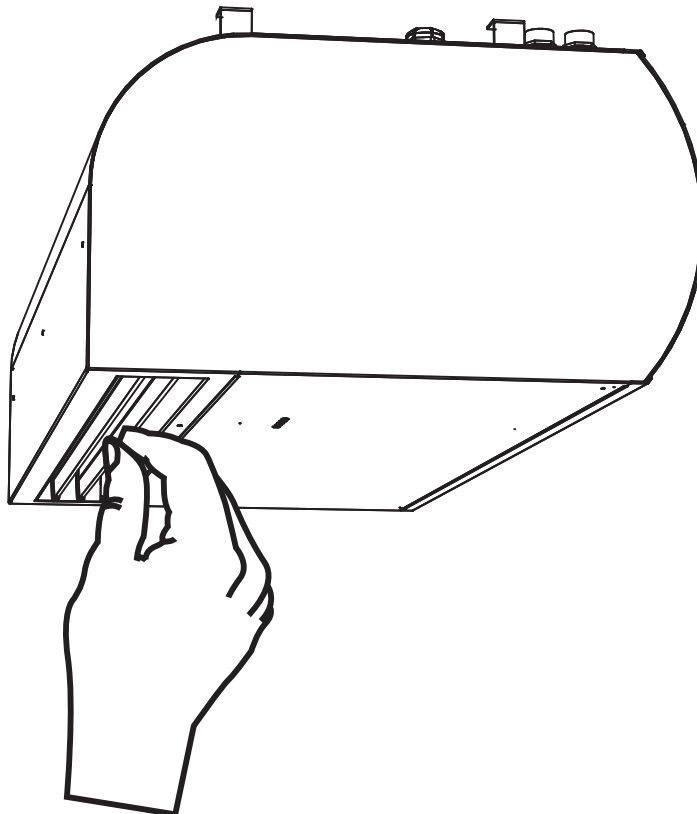

7. CLEANING AND MAINTENANCE

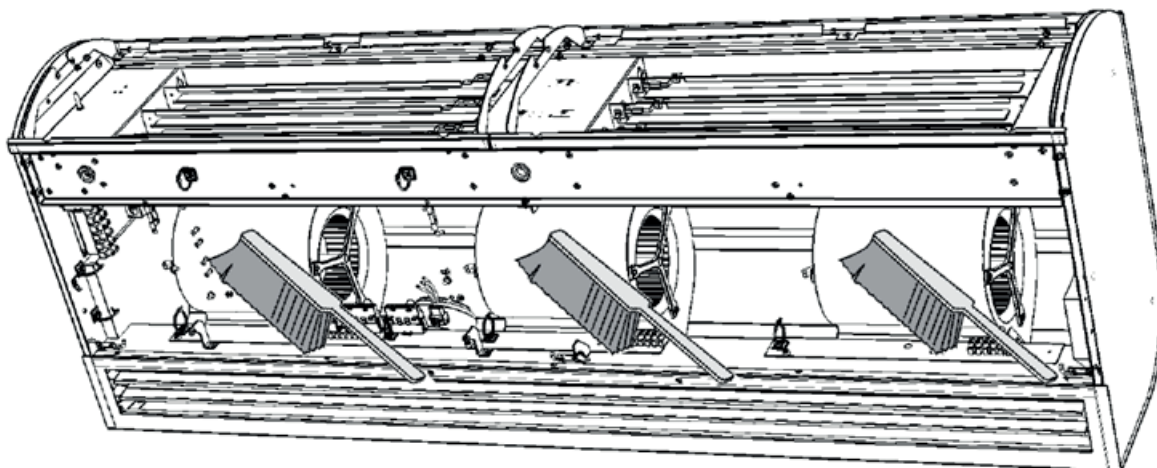
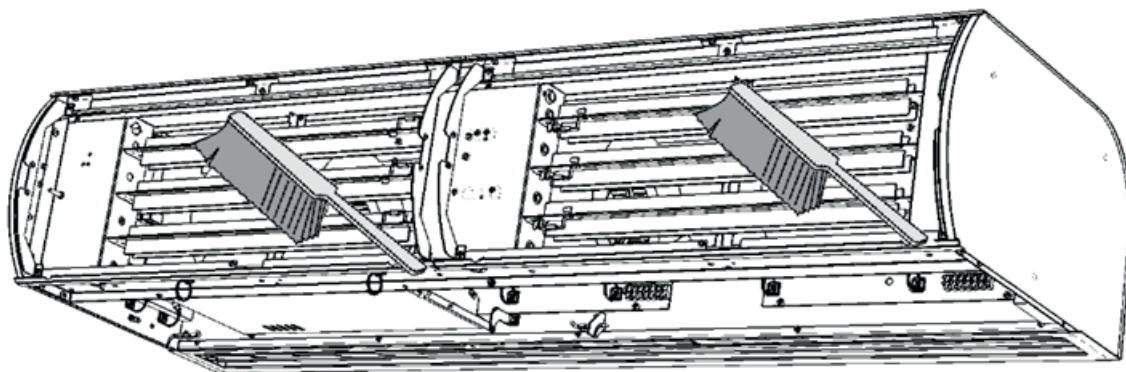
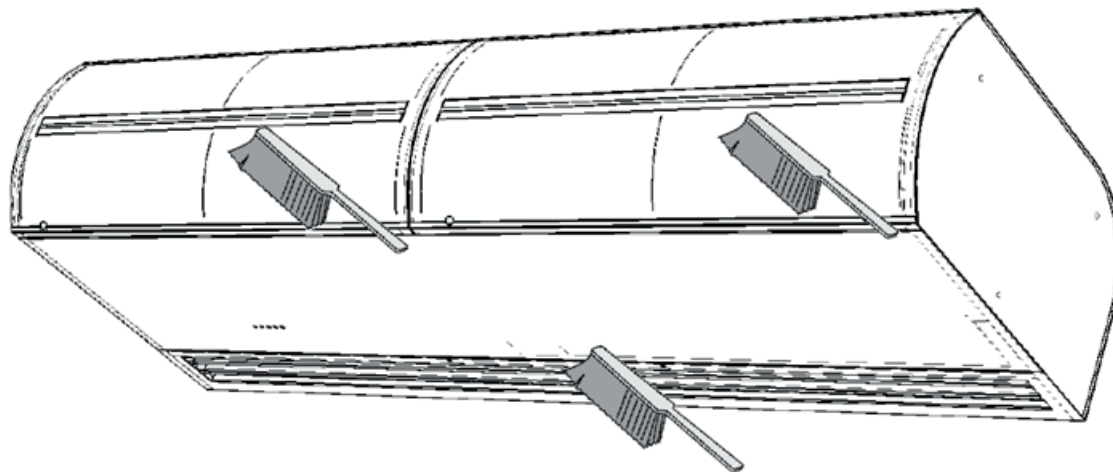

7. CLEANING AND MAINTENANCE

7.1 CLEANING



The main electrical supply must be switched off before any interference to the inside of the air curtain. The air curtain must be allowed to cool down!

Cleaning is forbidden to use compressed air, aggressive chemicals, solvents or water.

Clean with a damp cloth, a soft cloth, or a vacuum cleaner.

Clean the surface of the air curtain, including the suction part.

Perform cleaning as needed, recommended at least every 3 months.

Observe safety and use protective equipment.

8. SERVIS

8.1 WHEN YOU AREN'T ABLE TO REMOVE DEFECT BY YOURSELF

If you are unable to resolve the problem, contact the supplier.

For the fast removal of defects please provide the following information:

- product reference number
- serial number
- running time
- used accessories
- installation location
- installation condition (including electrical)
- detailed description of the problem and the steps that you have taken for its removal

Warranty and post-warranty service is performed by the manufacturer, supplier or authorized service organization.

When ordering service intervention it is necessary to describe the defect, product type designation indicated on its label, and the location of installation.

8.2 PUTTING THE PRODUCT OUT OF OPERATION - DISPOSAL

Before disposing of the product, make the product unusable. Even old products contain raw materials that can be reused. Take them to a collection point of secondary raw materials.

The product is good to dispose at the place, which is specialized for it, and thus it will be possible to recycle materials. Store unusable parts of the product at a controlled dump.



When disposing of materials, it is necessary to observe the relevant national regulations on waste disposal.

9. ELECTRICAL SCHEMES

Types without heating - VCS4-B-xxx-S...

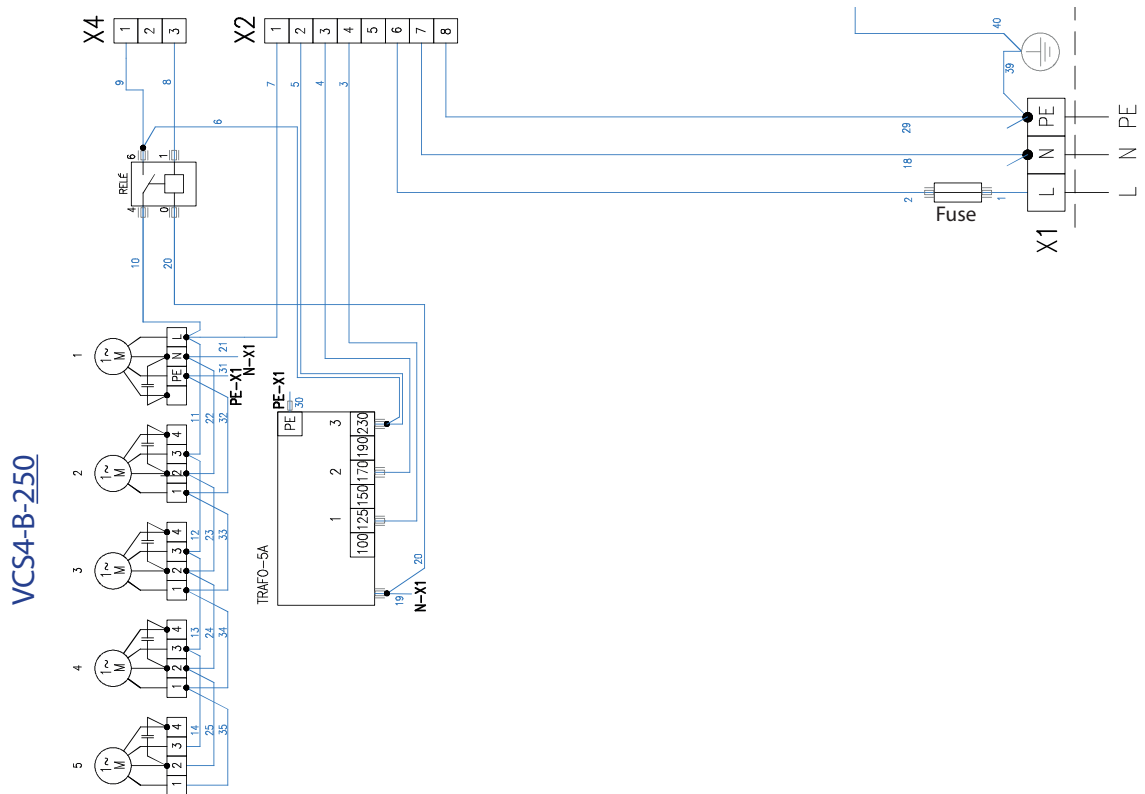
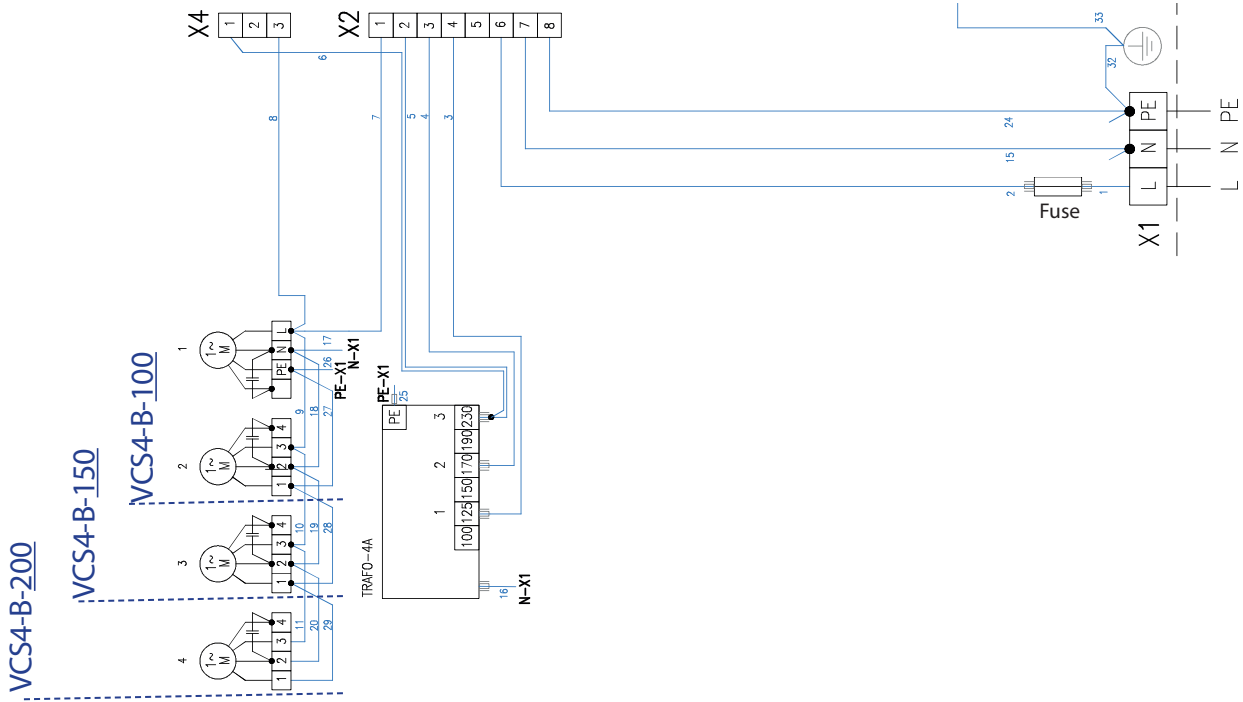

9. ELECTRICAL SCHEMES

Types with water coil VCS4-B-xxx-V(W)-...

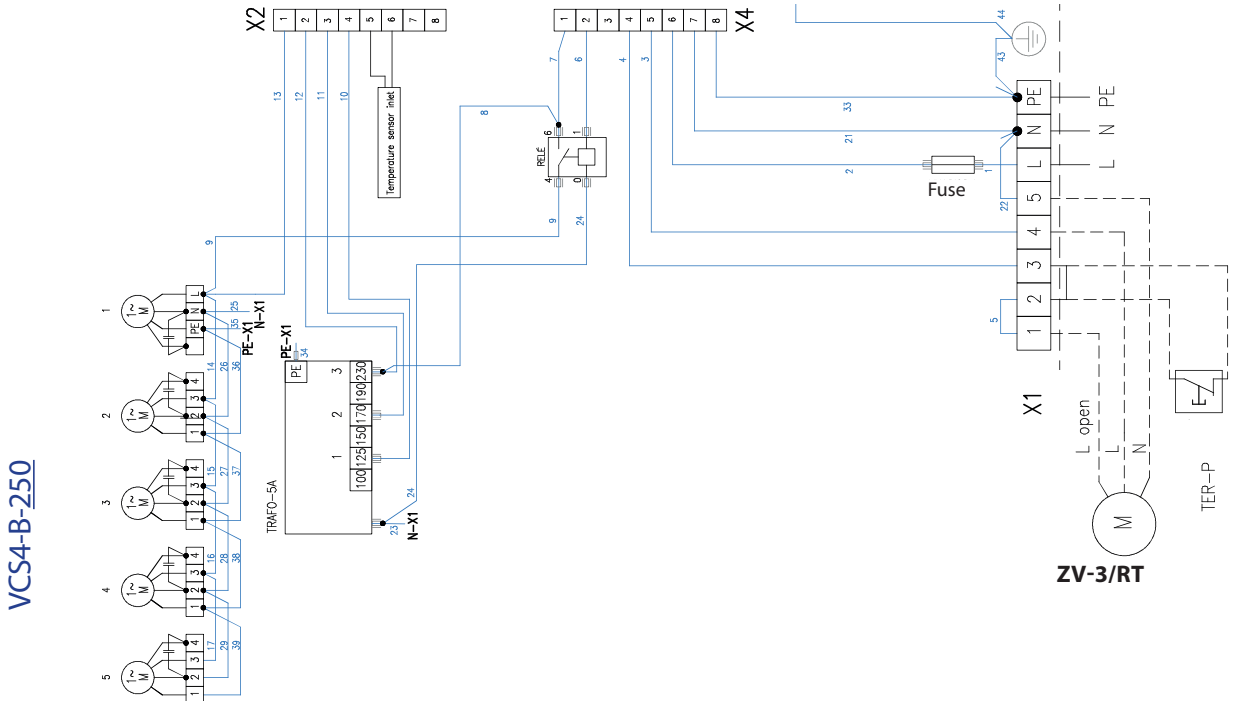
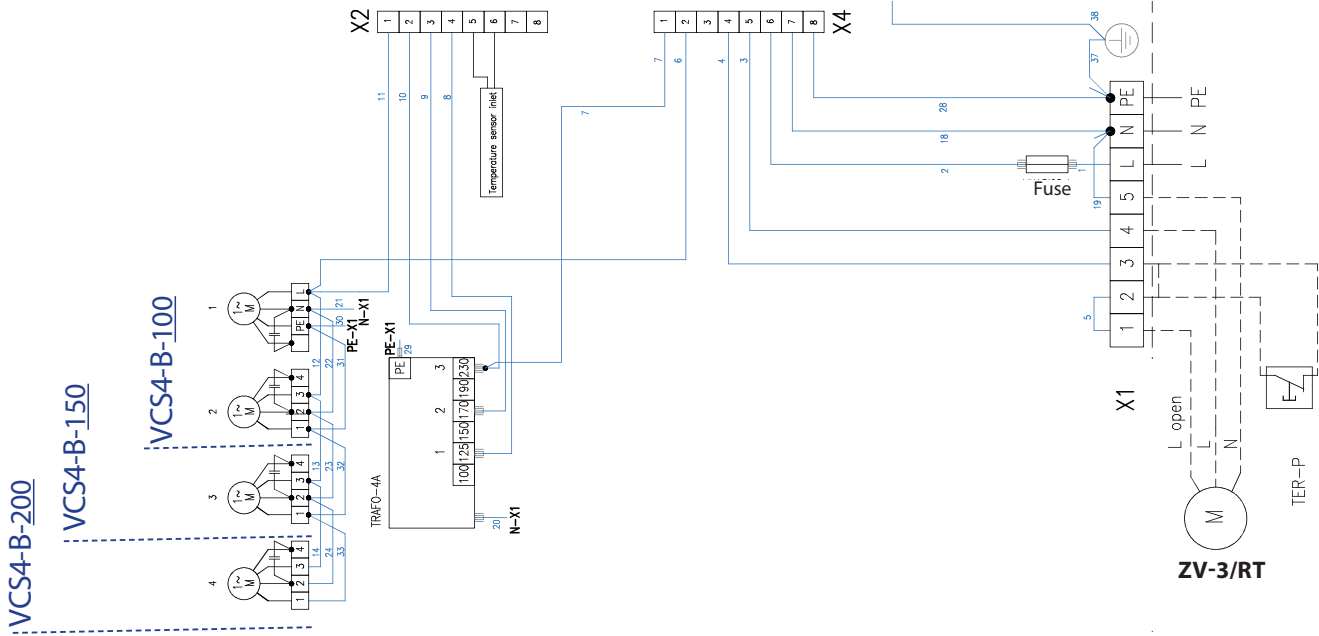

9. ELECTRICAL SCHEMES

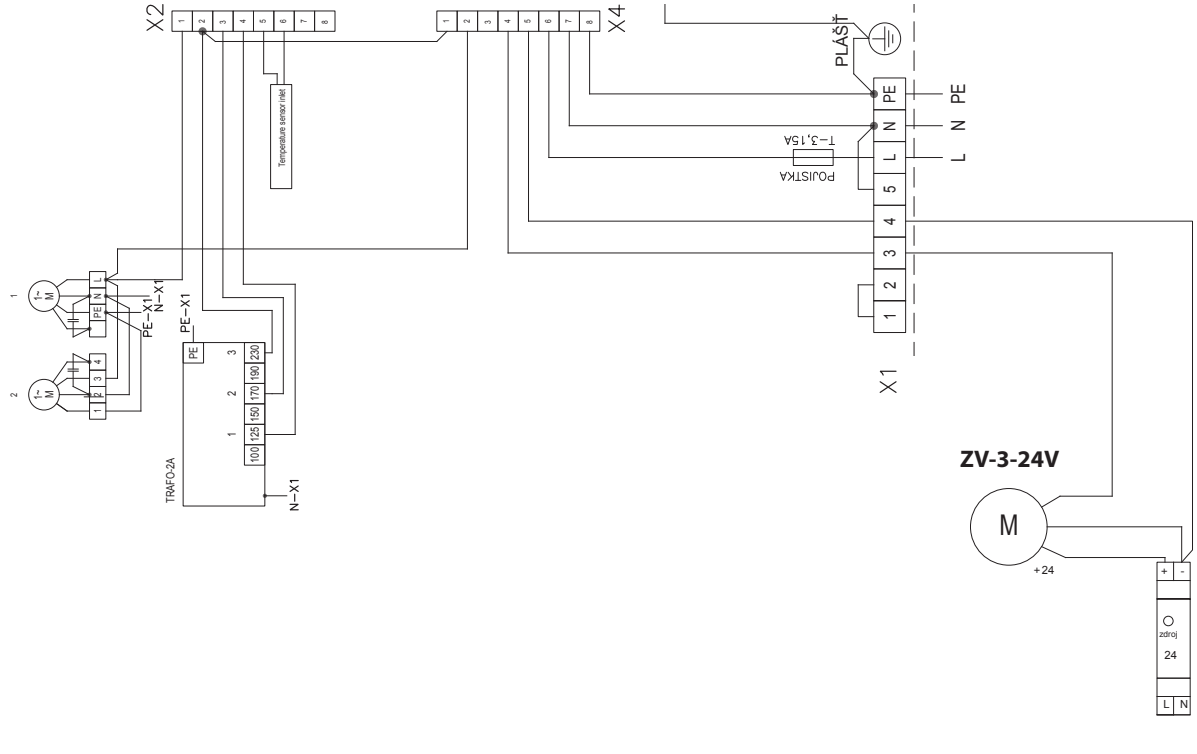

9. ELECTRICAL SCHEMES

Types with electric heater VCS4-B-xxx-E-...

VCS4-B-100-E-...

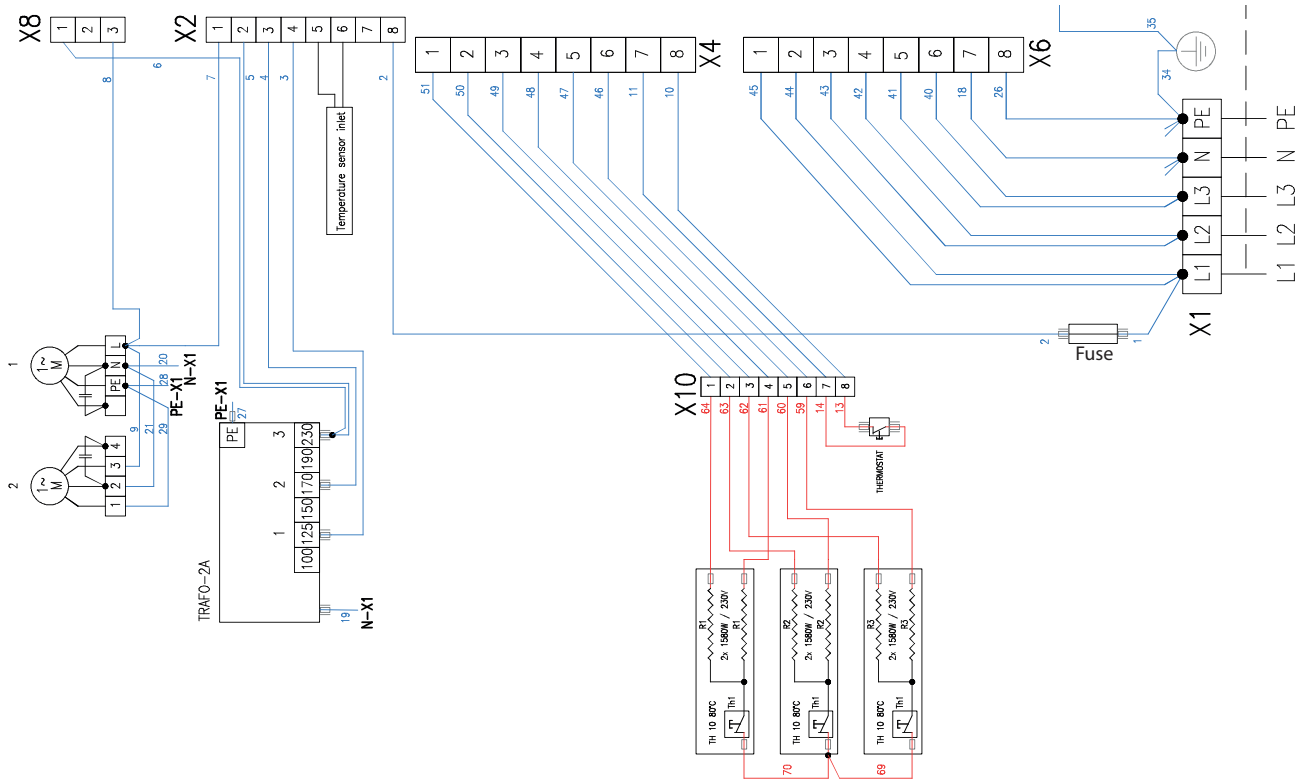

VCS4-B-150-E-...

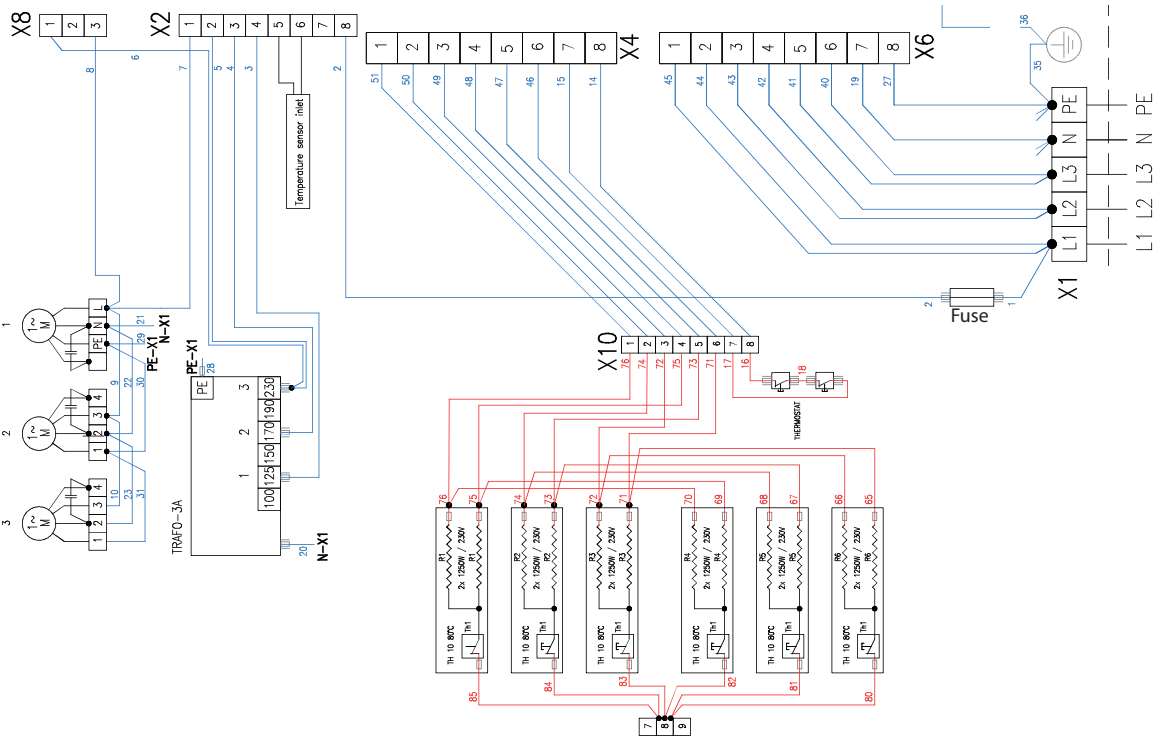

9. ELECTRICAL SCHEMES

VCS4-B-200-E-...

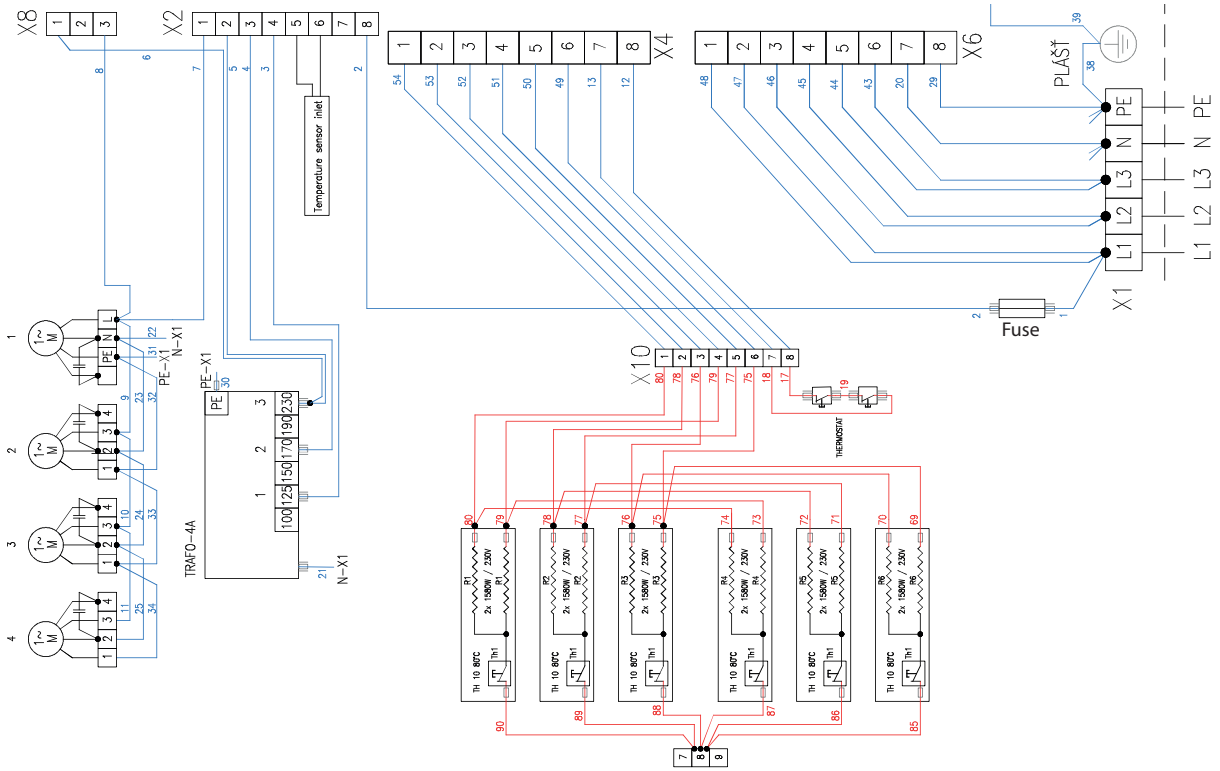

VCS4-B-250-E-...

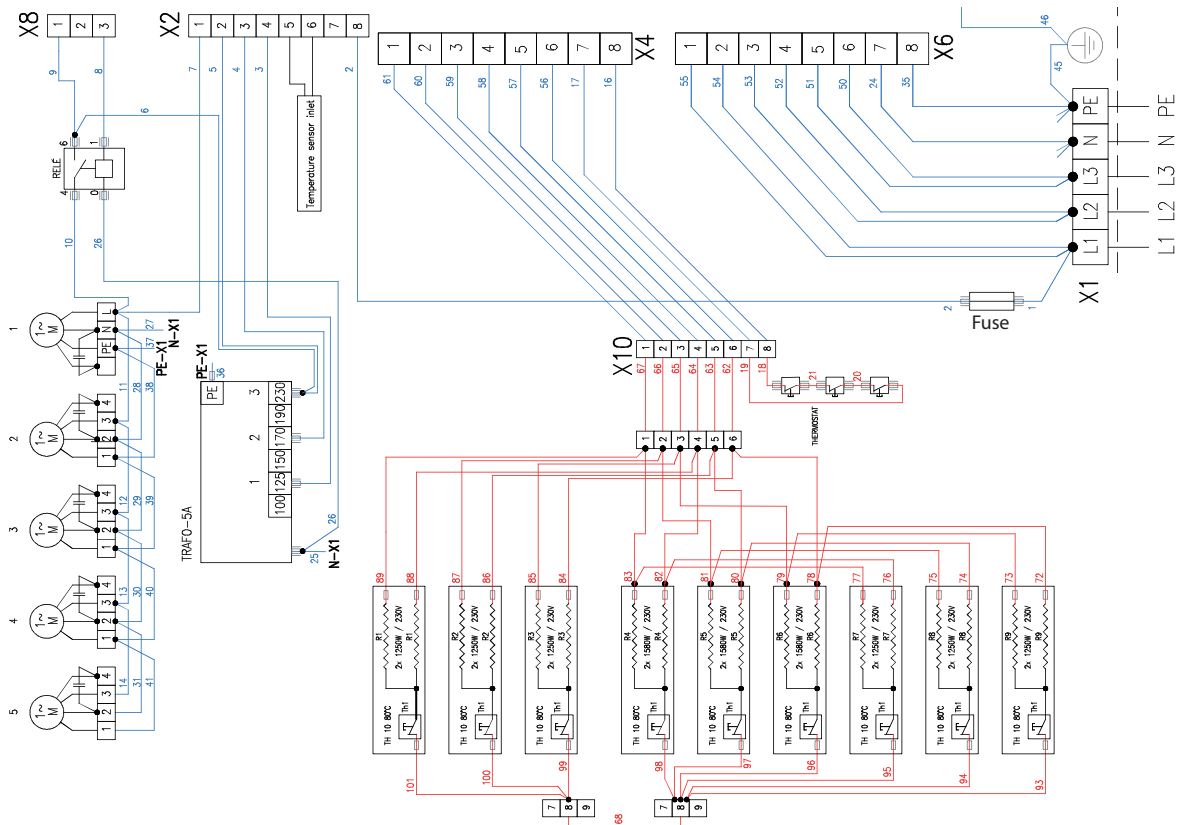

9. ELECTRICAL SCHEMES

Types without heating - VCS4-C-...-S-...
 VCS4-C-100-S-...

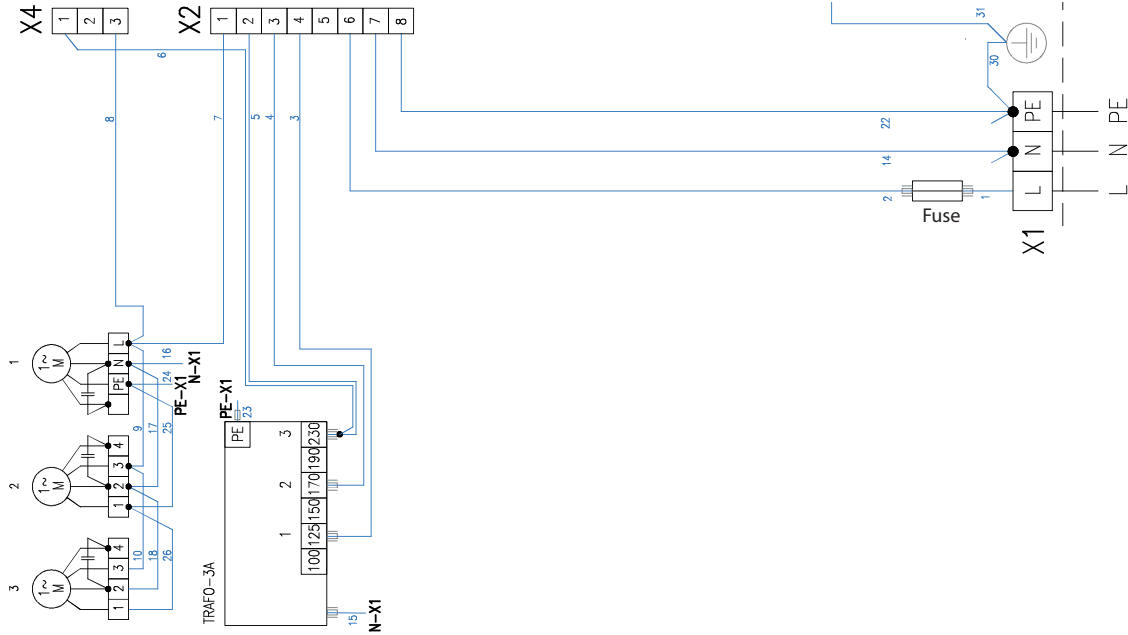

VCS4-C-...-S-...

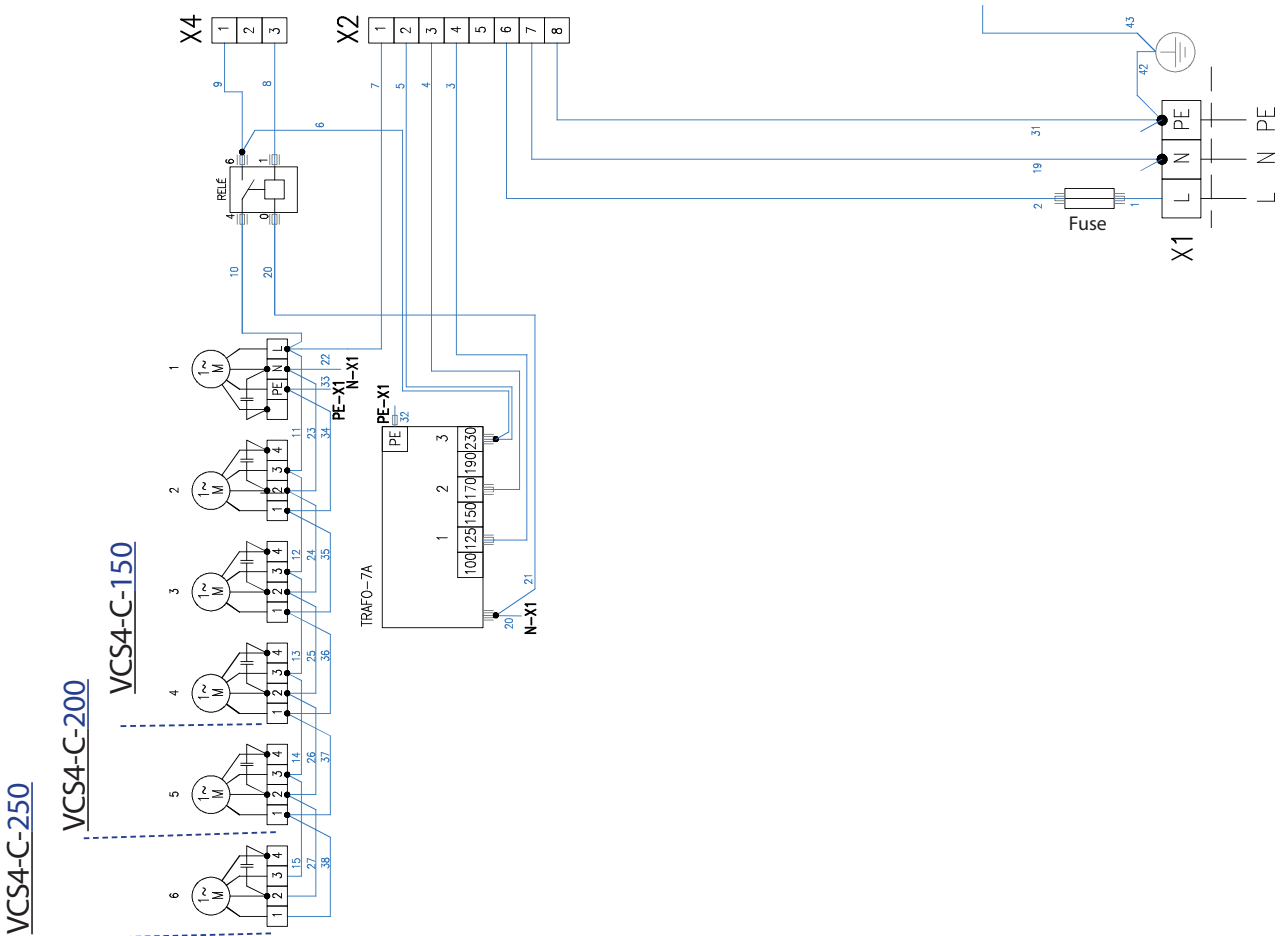

9. ELECTRICAL SCHEMES

Types with water coil VCS4-C-xxx-V(W)-...
VCS4-C-100-V(W)-...

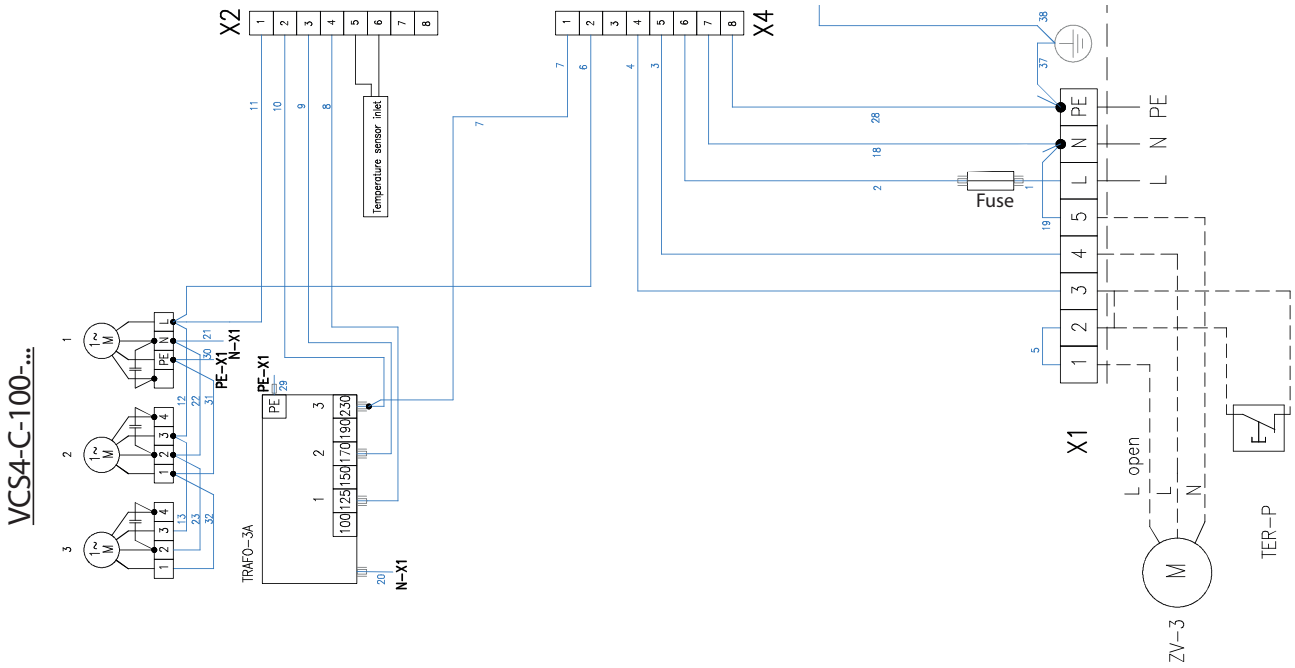

VCS4-C-...-V(W)-...

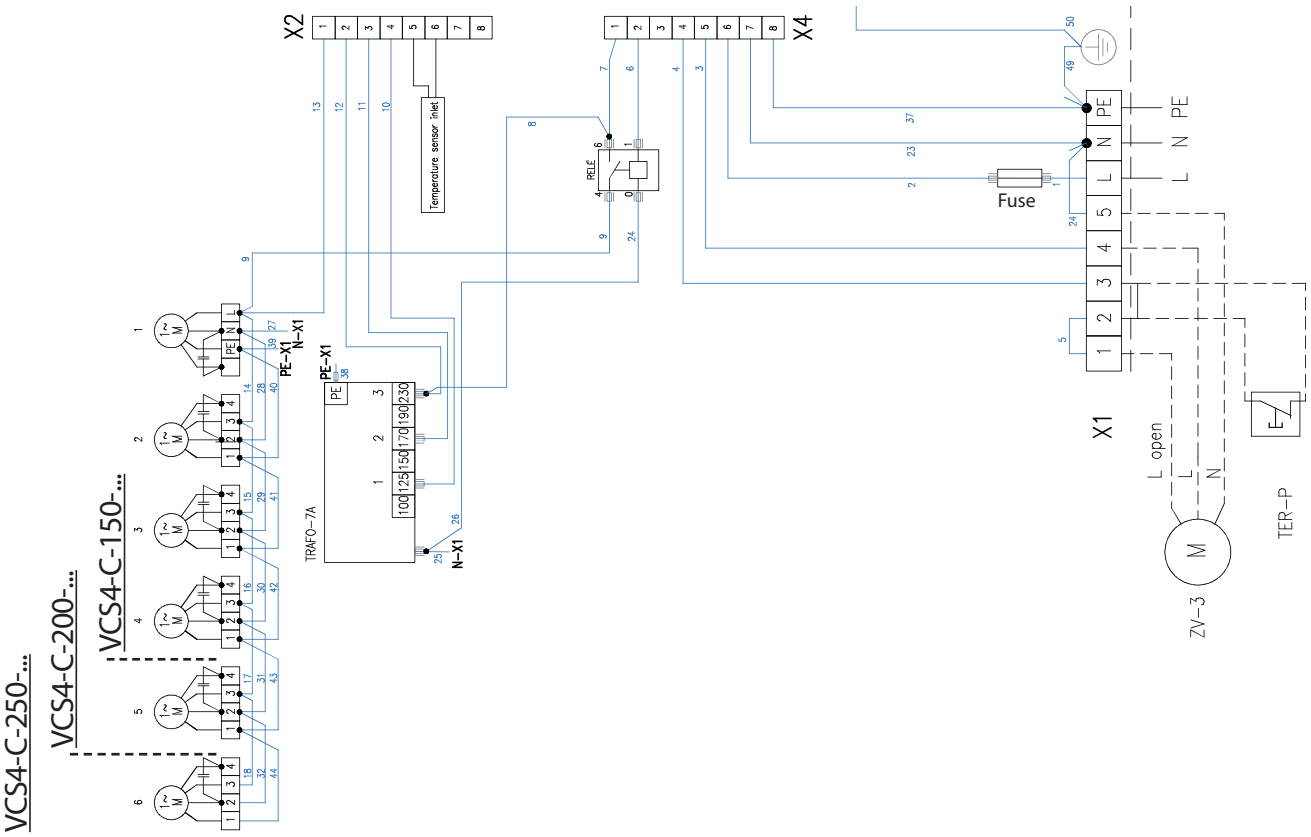

9. ELECTRICAL SCHEMES

Types with electric heater VCS4-C-xxx-E-...

VCS4-C-100-E-...

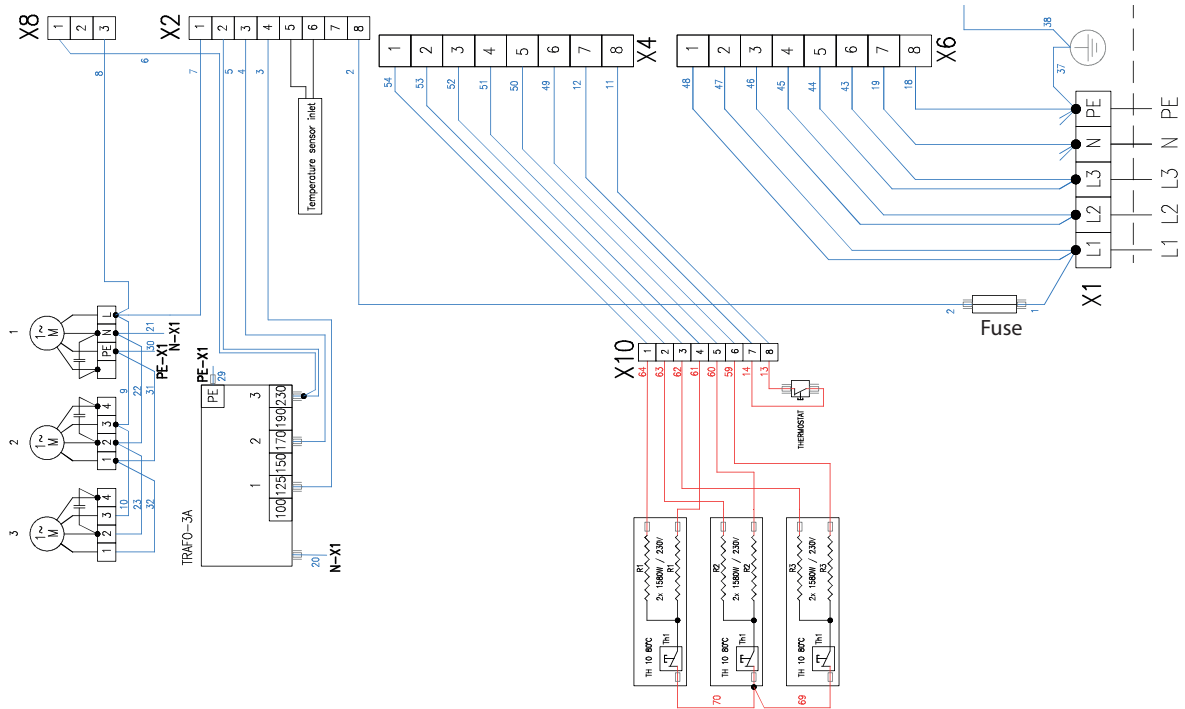

VCS4-C-150-E-...

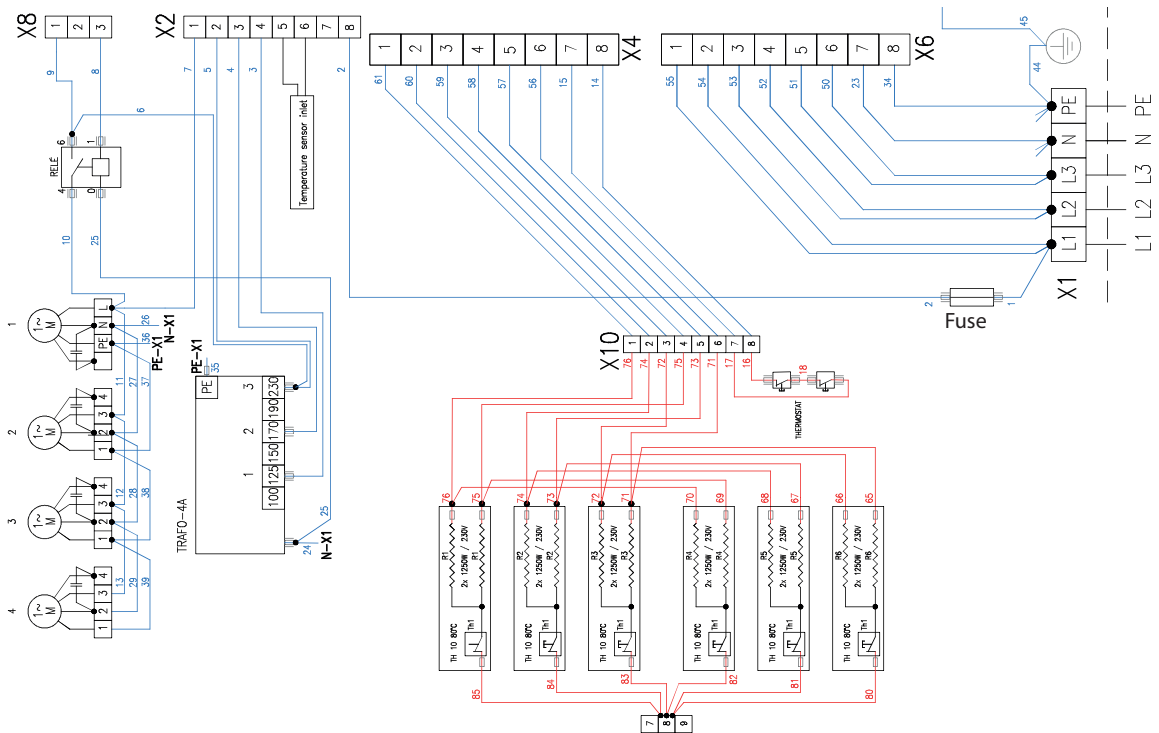

9. ELECTRICAL SCHEMES

VCS4-C-200-E-...

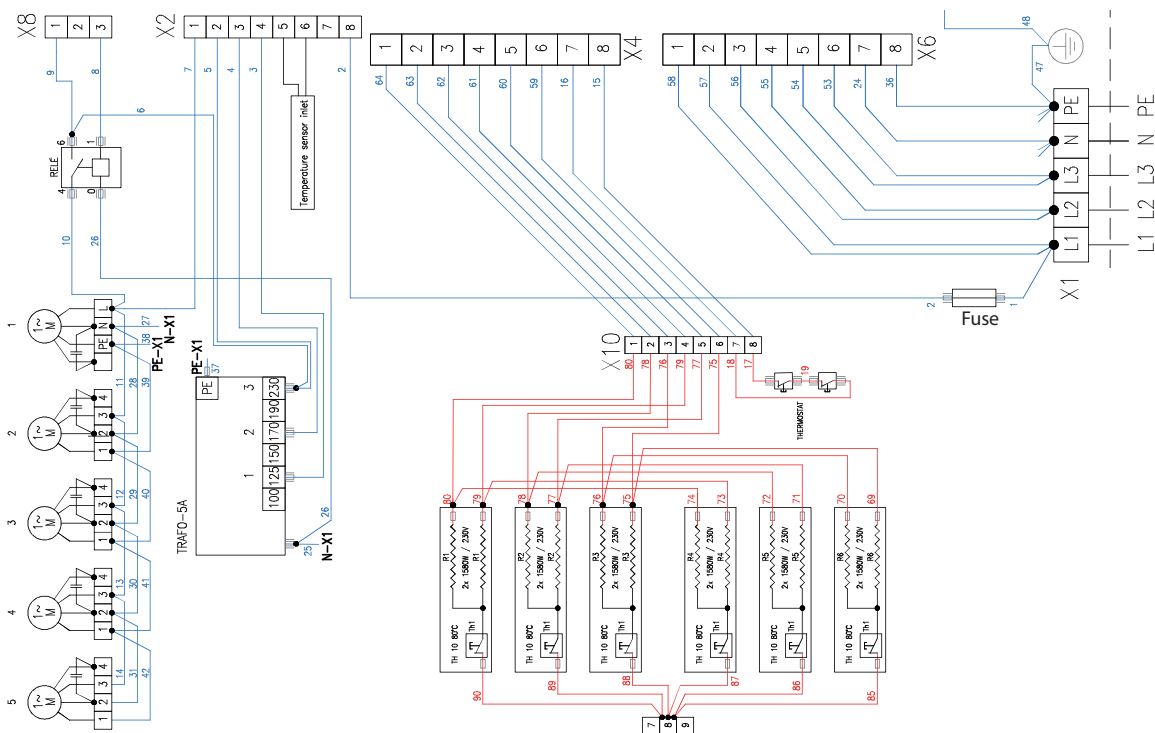

VCS4-C-250-E-...

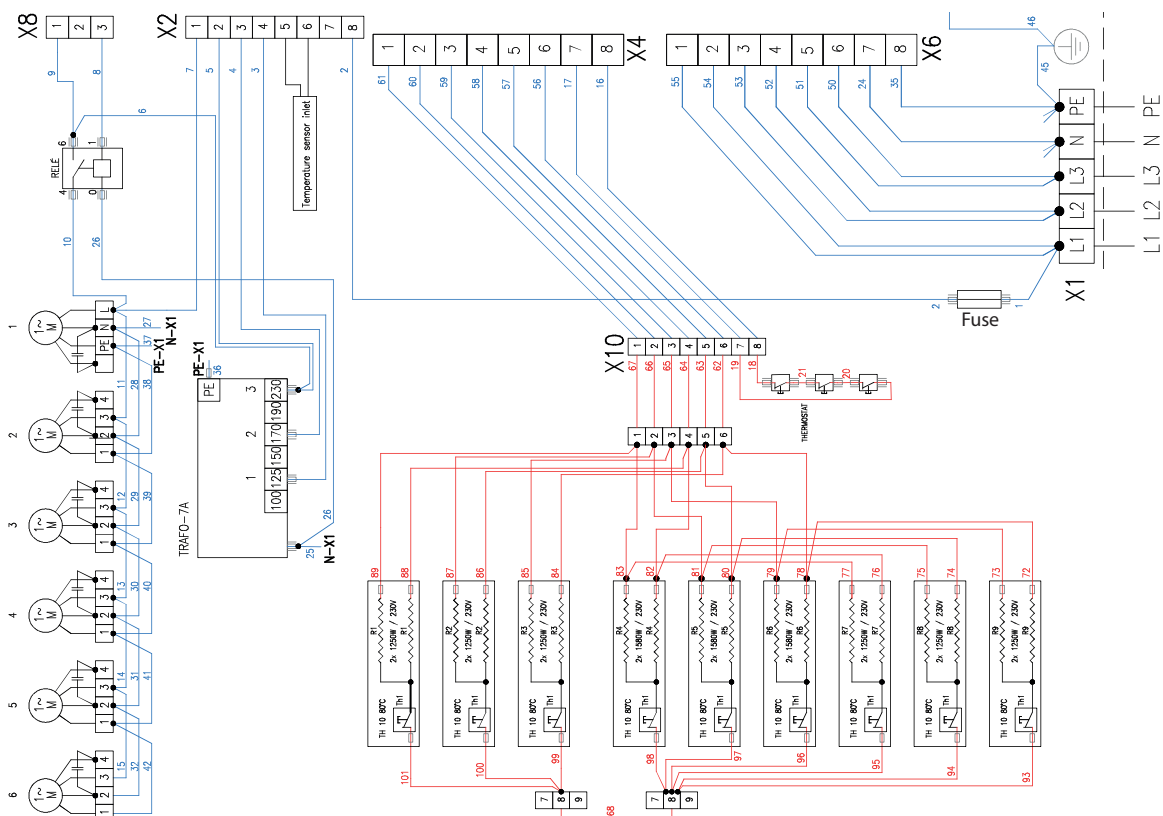

10. CONCLUSION

After installing the air curtain, read carefully the **Manual for the appropriate regulator**. In case of any doubt or query, do not hesitate to contact our sales or technical support departments.

CONTACT

Address:

2VV, s.r.o.,
Fáblovka 568,
533 52 Pardubice,
Česká republika

Internet:

<http://www.2vv.cz/>

